

Contract Bid Documents

verdantas



KENNEDY MANOR – WASTE PIPE REPLACEMENTS

Project Number.: 16965
Procurement and Contract Bidding
Project Specifications | 175 Broad Street, Pawtucket, RI 02860

October 2024

Prepared for:
Pawtucket Housing Authority
214 Roosevelt Avenue
Pawtucket, RI 02860



Prepared by:
Verdantas, LLC
1005 Main Street, Suite #8120
Pawtucket, RI 02860

verdantas

TABLE OF CONTENTS

DIVISION 00 – BIDDING AND CONTRACT REQUIREMENTS

Invitation to Bid
Information to Bidders
Bid Proposal Forms
Bid Bond Form
Proposed Subcontractors Form
Statement of Experience Form
Contract Agreement
Payment Bond
Performance Bond
Notice of Award
Notice to Proceed
Prevailing Wage Rates
HUD Documents
General Conditions
Special Conditions

DIVISION 01 – GENERAL REQUIREMENTS

01000	Summary of Work
01150	Measurements and Payments
01175	Temporary Facilities
01200	As-Built Drawings
01300	Submittals
01400	Quality Control
01600	Delivery Storage and Handling

APPENDICES

Appendix A	Design Plans
------------	--------------

DIVISION 00 – BIDDING AND CONTRACT REQUIREMENTS

*Pawtucket Housing Authority
Kennedy Manor Waste Pipe Replacements
Pawtucket, Rhode Island*

Pawtucket Housing Authority
ADVERTISEMENT FOR BIDS
Kennedy Manor Waste Pipe Replacements

Sealed bids for the **Pawtucket Housing Authority, Kennedy Manor Waste Pipe Replacements** will be received at the Pawtucket Housing Authority (PHA) until **11:00 AM on Monday November 18, 2024**. Each sealed bid needs to be marked on the outside of the envelope "Pawtucket Housing Authority, Kennedy Manor Waste Pipe Replacements Project". This project is subject to prevailing wage rates. Minority and women owned businesses are encouraged to submit bids.

The Pawtucket Housing Authority, Kennedy Manor Waste Pipe Replacements Project work encompassed under this Contract shall include, but not limited to, establishing a perimeter around specified work area, posting proper signage of possible hazards on site, filing for applicable State and Local permits, demolition and legal disposal of existing waste pipe, replacement of waste pipe with new schedule 40 PVC pipes, repair of drywall and associated painting, all as shown on the contract documents, and providing all materials, labor, tools and incidentals necessary to complete the work of this contract to the satisfaction of the Owner.

The Bidder must agree to commence work and fully complete the work of this Contract on the dates specified in the contract documents. The Bidder must agree also to pay liquidated damages for each consecutive calendar day thereafter as hereinafter provided in the Contract and General Conditions. **The bidder must be registered on SAM.gov (<https://sam.gov/content/home>).**

BID SECURITY in the form of bid bond, certified check, treasurer's check or cashier's check in the amount of 5(%) percent of the bid amount must accompany each Bid. No bidder may withdraw his Bid within 90 days after the actual date of the opening thereof.

Plans and Bid Documents are available on the website of the Pawtucket Housing Authority (pawthousing.org) under Bids/RFPs tab starting on **Tuesday, October 8, 2024**. It will be the Bidders responsibility to check the website for any addendum posted.

There will be a **non-mandatory** pre-bid conference on **Monday, November 4, 2024, at 11:00 AM** at the Project Site, Kennedy Manor, 175 Broad Street, Pawtucket RI.

Successful bidder must furnish 100% Performance Bond and 100% Labor and Material Payment Bond and the required insurance certificates and execute the Agreement within (10) calendar days following notification of the Acceptance of his/her Bid.

The Pawtucket Housing Authority reserves the right to reject any and all bids, to waive any technical or legal deficiencies, to accept individual bid items and excluding others, and to accept any a bid that it may deem to be in the best interest and most responsive of the Owner.

Attention of the bidders is particularly called to the requirements as to conditions of employment to be observed and minimum wage rates to be paid under the Contract. In conformity with the Provisions of Chapter 13 of Title 37, General Laws, Rhode Island, 1956, as amended, the minimum wages for a day's work paid to craftsmen, teamsters and laborers shall be not less than the customary and prevailing rate of wages for a day's work in the locality where the work is undertaken. Such a schedule of wages has been established on a minimum hourly basis and is on file in the office of the State Department of Labor.

All questions shall be submitted in writing via email to Roy Messier, Senior Project Engineer of Verdantas, LLC, 401-728-6860. email: rmessier@verdantas.com by **Wednesday November 6, 2024, at 3:00 PM**. Upon receipt of any written questions, an addendum will be issued to all bidders on **Friday November 8, 2024**.

*Pawtucket Housing Authority
Kennedy Manor Waste Pipe Replacements
Pawtucket, Rhode Island*

Invitation to Bid - 1

INFORMATION TO BIDDERS

*Pawtucket Housing Authority
Kennedy Manor Waste Pipe Replacements
Pawtucket, Rhode Island*

Information to Bidders - 1

INFORMATION TO BIDDERS

1. RECEIPT AND OPENING OF BIDS
2. PREPARATION OF BID
3. TELEGRAPHIC MODIFICATION
4. CORRECTIONS
5. WITHDRAWAL OF BIDS
6. QUALIFICATIONS OF THE BIDDER
7. OBLIGATIONS OF THE BIDDER
8. CONDITIONS OF WORK
9. INFORMATION SUPPLIED TO BIDDERS
10. BID SECURITY
11. METHOD OF AWARD
12. EXECUTION OF THE AGREEMENT
13. LIQUIDATED DAMAGES FOR FAILURE TO ENTER INTO CONTRACT
14. NOTICE TO PROCEED
15. TIME OF COMPLETION AND LIQUIDATED DAMAGES
16. POWER OF ATTORNEY
17. ADDENDA AND INTERPRETATIONS
18. NOTICE OF SPECIAL CONDITIONS
19. LAWS AND REGULATIONS
20. MANUFACTURER'S EXPERIENCE
21. ACCESS TO SITE
22. SOIL BORINGS
23. RHODE ISLAND SALES AND USE TAX
24. JOB CONDITIONS
25. PRECONSTRUCTION CONFERENCE
26. LABOR REGULATIONS
27. PRE BID CONFERENCE

ARTICLE 1: RECEIPT AND OPENING OF BIDS

Sealed Bids for the work will be received and opened at the time and place indicated in the ADVERTISEMENT FOR BIDS.

Each Bid must be submitted in duplicate in a sealed envelope addressed to Pawtucket Housing Authority, 214 Roosevelt Avenue, Pawtucket RI 02860 and clearly labeled "**Pawtucket Housing Authority, Kennedy Manor Waste Pipe Replacements Project**" and bear the Title, Date and Time of Opening in the lower left corner. The envelope shall also bear the name and address of the Bidder.

If forwarded by mail, the sealed envelope containing the Bid must be enclosed in a second sealed envelope addressed to the Pawtucket Housing Authority, 214 Roosevelt Avenue, Pawtucket RI, 02860 and labeled "**Pawtucket Housing Authority, Kennedy Manor Waste Pipe Replacements Project**" as above. All bids forwarded by mail must be received in the office of PHA no later than **11:00 A.M. November 18, 2024.**

The Owner may consider informal any bid not prepared and submitted in accordance with the provisions hereof and may waive any informality in or reject any and all bids. Conditional or qualified bids will not be accepted. Any bid received after the time and date specified shall not be considered. Should there be reasons why the Contract cannot be awarded within the specified period; the time may be extended by mutual agreement between the Owner and the bidder.

ARTICLE 2: PREPARATION OF BID

Each bid must be filled out on the prescribed forms. All blank spaces for bid prices must be filled in, in ink or typewritten, both in words and figures. All bids must be prepared in conformity with and shall be based on and submitted subject to all requirements of the Specifications and Drawings, together with all Addenda thereto. **All documents must be filled out and submitted with bid.** Incomplete bids will be rejected.

ARTICLE 3: TELEGRAPHIC MODIFICATION

Any bidder may modify his bid by telegraphic communication at any time prior to the scheduled closing time for receipt of bids, provided such telegraphic communication is received by the Owner prior to the closing time, and provided further, the Owner is satisfied that written confirmation of the telegraphic modification over the signature of the bidder was mailed and postmarked prior to the closing time.

The telegraphic communication should not reveal the bid price but should provide the addition or subtraction or other modifications so that the final prices or items will not be known by the Owner until the sealed bid is opened. If written confirmation is not received prior to the bid closing time, no consideration will be given to the telegraphic modification.

ARTICLE 4: CORRECTIONS

Erasures or other changes in the bid must be explained or noted over the signature of the bidder.

ARTICLE 5: WITHDRAWAL OF BIDS

Bids may be withdrawn only on written request dispatched by the bidder in time for delivery in
*Pawtucket Housing Authority
Kennedy Manor Waste Pipe Replacements
Pawtucket, Rhode Island*

the normal course of business prior to the time fixed for the opening, provided that written confirmation of any withdrawal over the signature of the bidder is placed in the mail and postmarked prior to the time set for the opening of the bids. Negligence on the part of the bidder in preparing his bid confers no right of withdrawal or modification of his bid after such bid has been opened. No bidder may withdraw his bid within ninety (90) days after the actual date of the opening thereof.

ARTICLE 6: QUALIFICATIONS OF THE BIDDER

The Owner may make such investigations as he deems necessary to determine the ability of the bidder to perform the work, and the bidder shall furnish to the Owner all such information and data for this purpose as the Owner may request. The Owner reserves the right to reject any bid if the evidence submitted by, or investigation of, such bidder fails to satisfy the Owner that such bidder is properly qualified to carry out the obligations of the Contract and to complete the work contemplated therein. **The bidder must be registered on SAM.gov (<https://sam.gov/content/home>).**

ARTICLE 7: OBLIGATIONS OF THE BIDDER

Bidders must satisfy themselves by personal examination at the site of the proposed work, by review of the Drawings and the Specifications including Addenda, and by such other means as they may prefer, as to the actual conditions, requirements, and limits of the proposed work, and as to the accuracy of the information and statements herein contained. The submission of any bid will be accepted by the Owner as satisfactory proof that the bidder has satisfied himself in these respects. The bidder shall not at any time after the submission of a bid dispute or complain of such statements or information, nor assert that there was any misunderstanding in regard to the nature, or amount of work to be done. The failure or omission of any bidder to examine any form, instrument or document shall in no way relieve the bidder of his obligation to furnish all materials and labor necessary to carry out the provisions of the Contract Documents and to complete the contemplated work for the considerations set forth in his bid, if his bid is accepted.

ARTICLE 8: CONDITIONS OF WORK

Insofar as possible, the Contractor, in carrying out his work, must employ such methods or means as will not cause any interruption of or interference with traffic, with the use of existing facilities and utilities, with the use of municipally or State or privately owned lands, or with the work being performed by others. The Contractor must satisfy himself by his own investigation and research as to the nature and location of the work, the general and local conditions, including, but not restricted to, those bearing upon the transportation, disposal, handling and storage of materials, water, electric power, roads, means of access, the construction and making of connections of the work to existing facilities and utilities, or other similar conditions at the site, the character of equipment and facilities needed preliminary to and during the prosecution of the work, requirements of owners and controlling authorities having jurisdiction over the various lands, existing structures, facilities and utilities, and all other conditions affecting the work to be done and labor and materials needed.

ARTICLE 9: INFORMATION SUPPLIED TO BIDDERS

The Owner shall provide to bidders prior to bidding all information that is pertinent to, and
*Pawtucket Housing Authority
Kennedy Manor Waste Pipe Replacements
Pawtucket, Rhode Island*

delineates and describes, the land owned and rights-of-way acquired or to be acquired. The Contract Documents contain the provisions required for the construction of the project. Information obtained from any officer, agent, or employee of the Owner or any other person shall not affect the risks or obligations assumed by the contractor or relieve him from fulfilling any of the conditions of the Contract. Any information given relating to subsurface and other conditions, natural phenomena, existing pipes and other structures is from the best sources available to the owner. All such information is furnished for the information and convenience of bidders and is not guaranteed.

ARTICLE 10: BID SECURITY

Each bid must be accompanied by a certified check of bidder, or a bid bond prepared on the form of bid bond attached hereto, duly executed by the bidder as principal and having as surety thereon a surety company approved by the Owner, in the amount of (5) Five (%) percent of the bid. Such checks or bid bonds will be returned to all but the selected bidder within three days after the Owner and the accepted bidder have executed the contract; or if no award has been made within 90 days after the date of the opening of the bids, upon demand of the bidder at any time thereafter, so long as he has not been notified of the acceptance of his bid. The check or bid bond of the successful bidder will be retained until the payment bond and performance bond have been executed and approved, after which it will be returned.

ARTICLE 11: METHOD OF AWARD

This contract will be awarded based on the lowest qualified bid, experience of the bidder, and most responsive bid that reflects the best product received by Pawtucket Housing Authority.

ARTICLE 12: EXECUTION OF THE AGREEMENT

A contract in the form set forth hereinafter will be required to be executed by the successful bidder and the Owner. The attention of all bidders, therefore, is called to the form of the Agreement and the provisions thereof. The party to whom the Contract is awarded will be required to obtain the performance bond and payment bond within ten (10) calendar days from the date when the Notice of Award is delivered to the bidder. The Notice of Award shall be accompanied by the necessary Agreement and bond forms. The Contractor shall furnish a performance bond and a payment bond, each in the amount of 100 percent of the Contract Price, with a corporate surety approved by the Owner, as security for faithful performance of Contract.

ARTICLE 13: LIQUIDATED DAMAGES FOR FAILURE TO ENTER INTO CONTRACT

The successful bidder, upon his failure or refusal to execute and deliver the Contract and bonds required within 10 days after he has received notice of the acceptance of his bid, shall forfeit to the Owner, as liquidated damages for such failure or refusal, the surety deposited with his bid.

ARTICLE 14: NOTICE TO PROCEED

The Notice to Proceed shall be issued within ten (10) days of the execution of the Agreement by the Owner. Should there be reasons why the Notice to Proceed cannot be issued within such period; the

*Pawtucket Housing Authority
Kennedy Manor Waste Pipe Replacements
Pawtucket, Rhode Island*

time may be extended by mutual agreement between the Owner and Contractor. If the Notice to Proceed has not been issued within the ten (10) day period or within the period mutually agreed upon, the Contractor may terminate the Agreement without further liability on the part of either party.

ARTICLE 15: TIME OF COMPLETION AND LIQUIDATED DAMAGES

The bidder must agree to commence construction work on the date specified in the written Notice to Proceed of the Owner and to fully complete the Project within **ninety (90) calendar days**. The Owner reserves the right to stop all work due to severe weather conditions, or other such conditions that may in his/her opinion interfere with the normal operation of the site and/or the safety of its occupants. The bidder must agree also to pay as liquidated damages, the sum of \$300.00 for each consecutive calendar day thereafter as hereinafter provided in the Contract and General Conditions.

ARTICLE 16: POWER OF ATTORNEY

Attorney-in-fact who sign bid bonds or contract bonds must file with each bond a certified and effectively dated copy of their power of attorney.

ARTICLE 17: ADDENDA AND INTERPRETATIONS

No interpretation of the meaning of the Drawings, Specifications, or other pre-bid documents will be made to any bidder orally. Every request for such interpretation should be in writing, addressed to Verdantas, LLC, 1005 Main Street, Suite #8120, Pawtucket, RI 02860; or via email to Roy Messier with Verdantas, LLC (rmessier@verdantas.com).

In order to be given consideration, such request must be made at least five- (5) workdays prior to the date fixed for the opening of bids. Any and all interpretations and any supplemental instructions will be in the form of written Addenda to the Specifications, which, if issued, will be transmitted electronically by email with return receipt requested to all prospective bidders, not later than three work days prior to the date fixed for the opening of bids. Failure of any bidder to receive any such addenda or interpretations shall not relieve the bidder from any obligation under his bid as submitted. All Addenda so issued shall become a part of the Contract Documents.

ARTICLE 18: NOTICE OF SPECIAL CONDITIONS

Attention is particularly called to those parts of the Contract Documents and Specifications that deal with the following:

- A. inspection and testing of materials
- B. insurance requirements
- C. wage rates
- D. interpretation of Drawings and Specifications

ARTICLE 19: LAWS AND REGULATIONS

The bidder's attention is directed to the fact that all applicable State laws, municipal ordinances and rules, and regulations of all authorities having jurisdiction over construction of the project shall apply to the Contract the same as though herein written in full.

*Pawtucket Housing Authority
Kennedy Manor Waste Pipe Replacements
Pawtucket, Rhode Island*

ARTICLE 20: MANUFACTURER'S EXPERIENCE

Wherever it may be written that an equipment manufacturer must have a specified period of experience with his product, equipment which does not meet the specified experience period may, at the option of the Owner, be considered if the equipment supplier or manufacturer is willing to provide a bond or cash deposit for the duration of the specified time period which will guarantee replacement of that equipment in the event of failure.

ARTICLE 21: ACCESS TO SITE

Representatives of the "OWNER" shall have access to the work wherever it is in preparation or progress and the Contractor shall provide proper facilities for such access and inspection.

ARTICLE 22: SOIL BORINGS

No Soil Borings for this Project

ARTICLE 23: RHODE ISLAND SALES AND USE TAX

Materials and equipment purchased for installation under this Contract are exempt from the Rhode Island Sales Tax. The exemption from the Sales Tax shall be taken into account by the Contractor during bidding.

ARTICLE 24: JOB CONDITIONS

The bidder is advised that free vehicular and pedestrian access must be maintained to the site at all times. The method of construction must be therefore compatible with this requirement of free access.

ARTICLE 25: PRECONSTRUCTION CONFERENCE

The Contractor shall be prepared to attend a pre-construction conference scheduled by the Owner after award of the Contract, but prior to the actual commencement of work at the site. The main item of discussion will be the Contractor's construction schedule, the proposed Superintendent, and access for residents.

ARTICLE 26: LABOR REGULATIONS

The following paragraphs regarding nondiscrimination in employment shall be included and become part of these Specifications:

- A. The Contract for work under this proposal will obligate the Contractor and Subcontractors not to discriminate in employment practices and conform to Executive Order No. 11246. The Contractor shall also comply with the Labor Standards Provisions for minimum wages and payroll certification.

*Pawtucket Housing Authority
Kennedy Manor Waste Pipe Replacements
Pawtucket, Rhode Island*

- B. Bidders must, if required, submit a compliance report concerning their employment practices and policies in order to maintain their eligibility to receive award of the Contract.
- C. Successful bidders must, if required, submit a list of all Subcontractors who will perform work on the project, and written signed statements from authorized agents of labor pools with which they will or may deal with for employees on the work, together with any information to the effect that such labor pools practices or policies are in conformity with Executive Order No. 11246; that they will affirmatively cooperate in or offer no hindrance to the recruitment, employment, and equal treatment of employment, and equal treatment of employees seeking employment and performing work under this Contract; or a certification as to when such agents or labor pools have failed or refused to furnish them, prior to award of the Contract.
- D. Contractor shall be required to submit certified payroll documentation when request to certify that wages are in compliance with the current wage rate determination.

ARTICLE 27: PRE BID CONFERENCE

There will be a **non-mandatory** pre-bid conference on **November 4, 2024 at 11:00 AM**, at the Project Site, located at 175 Broad Street, Pawtucket Rhode Island.

END OF INFORMATION TO BIDDERS

BID PROPOSAL

*Pawtucket Housing Authority
Kennedy Manor Waste Pipe Replacements
Pawtucket, Rhode Island*

Bid Proposal - 1

BID PROPOSAL

Proposal of _____ (hereinafter "Bidder"), organized and existing under the laws of the State of _____ doing business as _____ * to Pawtucket Housing Authority (hereinafter called "OWNER"):

In compliance with our Advertisement for Bids, BIDDER hereby proposes to perform all work for the Pawtucket Housing Authority, Kennedy Manor Waste Pipe Replacements Project in strict accordance with the CONTRACT DOCUMENTS, within the time set forth therein, and at the prices stated below.

By submission of this BID, each BIDDER certifies, and in the case of a joint BID each party thereto certifies as to his own organization, that his BID has been arrived at independently, without consultation, communication, or agreement as to any matter relating to this BID with any other BIDDER or with any competitor.

BIDDER hereby agrees to commence WORK under this Contract within 10 days of issue of a Purchase Order and Notice to Proceed. The contractor shall provide estimated days required to complete the project.

BIDDER acknowledges receipt of the following ADDENDA:

ADDENDUM _____ DATED:

ADDENDUM _____ DATED:

ADDENDUM _____ DATED:

* Insert "a corporation", "a partnership", or "an individual" as applicable.

NOTE, THE BID PROPOSAL DOCUMENTS INCLUDE THE BID PROPOSAL FORM, BID FORM, LISTING OF PROPOSED SUBCONTRACTORS, AND STATEMENT OF CONTRACTORS EXPERIENCE

*Pawtucket Housing Authority
Kennedy Manor Waste Pipe Replacements
Pawtucket, Rhode Island*

BID FORM

Note: The Price for each item must be written in words and figures

ITEM NO.	DESCRIPTION	ITEM QUANTITY	UNIT MEASURE	UNIT BID PRICE (\$0.00)	AMOUNT (QxP) (\$0.00)
-----------------	--------------------	----------------------	---------------------	--------------------------------	------------------------------

1.	Remove & Replace Existing Waste Pipes	88	EA	\$ _____	\$ _____
----	---------------------------------------	----	----	----------	----------

Total Amount in words: \$ _____

TOTAL \$ _____

Words: _____

ADD ALTERNATE BID FORM

Note: The Price for each item must be written in words and figures

ITEM NO.	DESCRIPTION	ITEM QUANTITY	UNIT MEASURE	UNIT BID PRICE (\$0.00)	AMOUNT (QxP) (\$0.00)
-----------------	--------------------	----------------------	---------------------	--------------------------------	------------------------------

1.	Hallway Painting Per Floor	8	EA	\$ _____	\$ _____
----	----------------------------	---	----	----------	----------

Total Amount in words: \$ _____

Bidder understands that the Owner reserves the right to reject any or all bids and to waive informalities in the bidding.

The Bidder agrees that this bid shall be good and may not be withdrawn for a period of 90 Calendar Days after the scheduled closing time for receiving bids.

Upon receipt of written notice of the acceptance of this Bid, Bidder will execute the formal contract attached within 10 days.

The undersigned declares; that the only person interested in this Proposal as principals are named herein as

*Pawtucket Housing Authority
Kennedy Manor Waste Pipe Replacements
Pawtucket, Rhode Island*

such; that no official of the Owner and no person acting for or employed by the Owner is interested directly or indirectly in this Proposal, or in any contract which may be made under it, or in any expected profits to arise there from; that this Proposal is made in good faith, without fraud, collusion or connection with any other person bidding or refraining from bidding for the same work; that he has examined carefully the said instructions and all other documents bound herewith, and the Contract Drawings relating to the contract covered by this Proposal and hereby makes them part of this Proposal; that he has informed himself fully in regard to all conditions pertaining to the work and place where it is to be done; and that he has made his own examination and carefully checked his estimates of cost and from them makes this Proposal.

The Owner reserves the right to accept individual bid items or combinations thereof.

In compliance with the requirements of Rhode Island General Law, Section 5-65-23, my Rhode Island license number for the work to be performed by this firm as prime contractor is:

License No. _____

(Signature of authorized representative)

(Title of authorized representative)

(Seal if bid is by a corporation)

(Business Address)

END OF DOCUMENT

BID BOND FORM

*Pawtucket Housing Authority
Kennedy Manor Waste Pipe Replacements
Pawtucket, Rhode Island*

Bid Bond - 1

BID BOND

KNOW ALL MEN BY THESE PRESENTS, that we, the undersigned _____, as Principal, and _____, as Surety, are hereby held and firmly bound unto Pawtucket Housing Authority, as OWNER in the penal sum of _____ (\$ _____), for the payment of which, well and truly to be made, we hereby jointly and severally bind ourselves, successors and assigns.

Signed, this _____ day of _____ 20__.

The condition of the above obligation is such that whereas the Principal has submitted to Pawtucket Housing Authority attached hereto and hereby made a part hereof to enter into a Contract in writing, for the **PAWTUCKET HOUSING AUTHORITY KENNEDY MANOR WASTE PIPE REPLACEMENTS**.

NOW, THEREFORE,

- (a) If said BID shall be rejected, or
- (b) If said BID shall be accepted and the Principal shall execute and deliver a Contract in the Form of Contract attached hereto (properly completed in accordance with said BID) and shall furnish a BOND for his faithful performance of said Contract, and for the payment of all persons performing labor or furnishing materials in connection therewith, and shall in all other respects perform the Agreement created by the acceptance of said BID.

Then this obligation shall be void, otherwise the same shall remain in force and effect; it being expressly understood and agreed that the liability of the Surety for any and all claims hereunder shall, in no event, exceed the penal amount of this obligation as herein stated.

The Surety, for value received, hereby stipulates and agrees that the obligations of said Surety and its

*Pawtucket Housing Authority
Kennedy Manor Waste Pipe Replacements
Pawtucket, Rhode Island*

BOND shall be in no way impaired or affected by any extension of the time with which the OWNER may accept such BID; and said Surety does hereby waive notice of any such extension.

IN WITNESS WHEREOF, the Principal and the Surety have hereunto set their hands and seals, and such of them as are corporations have caused their corporate seals to be hereto affixed and these presents to be signed by their proper officers, the day and year first set forth above.

Notary

_____ and

Principal

Seal

Surety

IMPORTANT: - Surety companies executing BONDS must appear on the Treasury Department's most current list (Circular 570 as amended) and be authorized to transact business in the State where the project is located.

PROPOSED SUBCONTRACTORS FORM

*Pawtucket Housing Authority
Kennedy Manor Waste Pipe Replacements
Pawtucket, Rhode Island*

Subcontractors -1

THE BIDDER SHALL STATE THE NAMES OF SUBCONTRACTORS
THAT HE PROPOSES TO USE
PROPOSED SUBCONTRACTORS

If none, write "None"

* Description of Work

Proposed Subcontractor, Name

Address

* Description of Work

Proposed Subcontractor, Name

Address

* Description of Work

Proposed Subcontractor, Name

Address

* Description of Work

Proposed Subcontractor, Name

Address

*Insert description of work and subcontractors' names as may be required.

This is to certify that all names of the above-mentioned subcontractors are submitted with full knowledge and consent of the respective parties.

The Bidder warrants that none of the proposed subcontractors have any conflict of interest as respects this Contract.

BIDDER

(FILL IN NAME)

BY

(Signature & Title)

*Pawtucket Housing Authority
Kennedy Manor Waste Pipe Replacements
Pawtucket, Rhode Island*

STATEMENT OF EXPERIENCE FORM

*Pawtucket Housing Authority
Kennedy Manor Waste Pipe Replacements
Pawtucket, Rhode Island*

Experience - 1

STATEMENT OF CONTRACTOR'S EXPERIENCE

The following experience sheet shall be completed by each Bidder, any bid submitted without a fully completed Experience sheet will be rejected by the Owner.

1. Have you ever failed to complete any work awarded to you?

If so, state where and why.

2. What similar projects has your organization completed within the last 5 years?

Class of Work	Contract Amount	When Completed	Name & Address of Engineer or Owner
(1)	(2)	(3)	(4)

CONTRACT AGREEMENT

*Pawtucket Housing Authority
Kennedy Manor Waste Pipe Replacements
Pawtucket, Rhode Island*

Agreement - 1

AGREEMENT

THIS AGREEMENT, made this _____ day of _____, 2024 by and between The Pawtucket Housing Authority, hereinafter called "OWNER" and _____ doing business as (an individual), or (a partnership), or (a corporation) hereinafter called "CONTRACTOR."

WITNESS TO: that for and in consideration of the payments and agreements hereinafter mentioned;

1. The CONTRACTOR will commence and complete the **Pawtucket Housing Authority Kennedy Manor Waste Pipe Replacements Project**.
2. The CONTRACTOR will furnish all of the material, supplies, tools, equipment, labor and other services necessary for the construction and completion of the PROJECT described herein.
3. The CONTRACTOR will commence the work required by the CONTRACT DOCUMENTS within 10 calendar days after the date of the NOTICE TO PROCEED and will complete the project within 90 calendar days unless the dates for completion are extended otherwise by the CONTRACT DOCUMENTS or scope of work is redefined by the Owner.
4. The CONTRACTOR agrees to perform all the WORK described in the CONTRACT DOCUMENTS and comply with the terms therein for the amount of \$ _____ as shown in the Bid Schedule.
5. The term "CONTRACT DOCUMENTS" means and includes the following:
 - A. REQUEST FOR BIDS
 - B. INFORMATION TO BIDDERS
 - C. BID PROPOSAL
 - D. FORM OF BID BONDS
 - E. PROPOSED SUBCONTRACTORS
 - F. STATEMENT OF EXPERIENCE
 - G. CONTRACT AGREEMENT
 - H. FORM OF PAYMENT BOND
 - I. FORM OF PERFORMANCE BOND
 - K. NOTICE OF AWARD
 - L. NOTICE TO PROCEED
 - GC GENERAL CONDITIONS
 - SC SPECIAL CONDITIONS
 - PW PREVAILING WAGE SHEET
 - HD HUD DOCUMENTS CONTAINED IN BID SPECIFICATIONS

Drawings and Technical Specifications prepared or issued by Verdantas, LLC dated October 2024.

Addenda:

No.	Dated	2024
No.	Dated	2024

6. The OWNER will pay the CONTRACTOR in the manner and at such times as set forth in the General Conditions such amounts as required by the Contract Documents.
7. Retention from progress payments will be in accordance with the requirements stipulated in the General Conditions.

*Pawtucket Housing Authority
Kennedy Manor Waste Pipe Replacements
Pawtucket, Rhode Island*

8. This Agreement shall be binding upon all parties hereto and their respective heirs, executors, administrators, successors and assigns.

IN WITNESS WHEREOF, the parties hereto have executed, or caused to be executed by their duly authorized officials, this Agreement in (Quadruplicate copies) each which shall be deemed an original on the date first above written.

OWNER: _____

BY: _____

NAME:

TITLE:

(SEAL)
WITNESS: _____

NAME: _____

TITLE: _____

CONTRACTOR: _____

BY: _____

NAME: _____

ADDRESS: _____

(SEAL)
WITNESS: _____

NAME: _____

TITLE: _____

PAYMENT BOND

*Pawtucket Housing Authority
Kennedy Manor Waste Pipe Replacements
Pawtucket, Rhode Island*

Bonds -1

LABOR AND MATERIAL PAYMENT BOND

KNOW ALL MEN BY THESE PRESENTS, that _____ (Name of Contractor)
of

(Address of Contractor)

as Principal hereinafter called Principal, and _____ of

(Name of Surety)

(Address of Surety)

_____, a Corporation, organized and existing under the laws of the State of _____, as Surety, hereinafter called Surety, are held and firmly bound unto Pawtucket Housing Authority, as Oblige, hereinafter called the Oblige, in the full penal sum of _____ dollars (\$ _____) in lawful money of the United States for the payment whereof Principal and Surety bind themselves, their heirs, executors, administrators, successors and assigns, jointly and severally, firmly by these presents.

THE CONDITION OF THIS OBLIGATION IS SUCH THAT WHEREAS said Principal has entered into a certain written contract with said Oblige, dated the _____ day of _____, 20____, which written contract provides for the **PAWTUCKET HOUSING AUTHORITY KENNEDY MANOR WASTE PIPE REPLACEMENTS** project which contract, together with all plans and specifications now made or which may hereafter be made in extension, modification or alteration thereof, are hereby referred to, incorporated in and made a part of this bond as though herein fully set forth.

NOW, THEREFORE, if the Principal shall promptly make payment to all persons, firms, subcontractors, and corporations furnishing materials for or performing labor in the prosecution of the work provided for in such contract, and any authorized extension or modification thereof, including all amounts due for materials, lubricants, oil, gasoline, coal and coke, repairs or machinery, equipment and tools, consumed or used in connection with the construction of such work, and all insurance premiums on said work and for all labor, performed in such work whether by subcontractor or otherwise, then this obligation shall be void; otherwise to remain in full force and effect.

PROVIDED, HOWEVER, that this bond is executed, pursuant to the provision of the General Statutes of the State of Rhode Island and the rights and liabilities hereunder shall be determined and limited by said sections to the same extent as if they were copies at length herein.

PROVIDED, FURTHER, that the said Surety for value received hereby stipulates and agrees that no change, extension of time, alteration or addition to the terms of the contract or to the work to be performed thereunder or the specifications accompanying the same shall in any wise affect its obligation on this bond, and it does hereby waive notice of any such change, extension of time, alteration or addition to the terms of the contract or to the work or to the specifications.

PROVIDED, FURTHER, that no final settlement between the Oblige and the Contractor shall abridge the right of any beneficiary hereunder, whose claim may be unsatisfied.

*Pawtucket Housing Authority
Kennedy Manor Waste Pipe Replacements
Pawtucket, Rhode Island*

IN WITNESS WHEREOF, the said principal and surety have signed and sealed this instrument this _____ day of _____, 20_____ .

ATTEST:

Principal

(Principal) Secretary

By

Witness as to Principal

ATTEST:

Surety

By _____
Attorney-in-Fact

(Surety) Secretary

(Seal)

Witness as to Surety

NOTE: Date of Bond must not be prior to date of Contract. If Contractor is Partnership, all partners should execute bond.

IMPORTANT: Surety companies executing Bond must appear on the Treasury Department's most current list (Circular 570 as amended) and be authorized to transact business in the State of Rhode Island.

*Pawtucket Housing Authority
Kennedy Manor Waste Pipe Replacements
Pawtucket, Rhode Island*

PEFORMANCE BOND

*Pawtucket Housing Authority
Kennedy Manor Waste Pipe Replacements
Pawtucket, Rhode Island*

PERFORMANCE BOND

KNOW ALL MEN BY THESE PRESENTS, that _____ (Name of Contractor)
of

(Address of Contractor)

as Principal hereinafter called Principal, and _____ of

(Name of Surety)

(Address of Surety)

_____, a Corporation, organized and existing under the laws of the State of hereinafter called Surety, are held and firmly bound unto the *Pawtucket Housing Authority*, called the Oblige, in the full penal sum of _____ Dollars (\$_____), in lawful money of their heirs, executors, administrators, successors and assigns, jointly and severally, firmly by these presents.

THE CONDITION OF THIS OBLIGATION IS MUCH THAT WHEREAS said Principal has entered into a certain written contract with said Oblige, dated the _____ day of _____, 20____ for the **PAWTUCKET HOUSING AUTHORITY KENNEDY MANOR WASTE PIPE REPLACEMENTS** project which contract, together with all Contract Documents now made or which may hereafter be made in extension, modification or alternation thereof, are hereby referred to, incorporated in and made a part of this bond as though herein fully set forth.

NOW, THEREFORE, if the said Principal shall well and truly keep, perform and execute all the terms, conditions and stipulations of said contract according to its provisions on his or its part to be kept and performed and shall indemnify and reimburse the Oblige for any loss that it may suffer through failure of the principal to faithfully observe and perform each and every obligation and duty imposed upon the Principal by the said contract, at the time and in the manner therein specified, then this obligation shall be null and void, otherwise it shall remain and be in full force and effect.

PROVIDED, HOWEVER, that any alternations which may be made in the terms of said contract or in the work done or to be done under it, or the giving by the Oblige of any extension of time for the performance of said Contract or any other forbearance on the part of either the Oblige or the Principal one to the others, shall not in any way released the Principal and/or the Surety, or either of them, their representative, heirs executors, administrators, successors or assigns from liability hereunder, notice to the Surety or Sureties of any such alteration, extension or forbearance being hereby specifically and absolutely waived.

AND PROVIDED FURTHER THAT NO ACTION, suit or proceeding shall be had or maintained against the Surety on this instrument unless the same be brought or instituted and process served upon the Surety within three years from the expiration of the guaranty period provided in the contract, whether the work be completed by the Principal, or Oblige.

*Pawtucket Housing Authority
Kennedy Manor Waste Pipe Replacements
Pawtucket, Rhode Island*

IN WITNESS WHEREOF, the said principal and surety have signed and sealed this instrument this _____ day of _____, 20_____ .

ATTEST:

Principal

(Principal) Secretary

By

Witness as to Principal

ATTEST:

Surety

By _____
Attorney-in-Fact

(Surety) Secretary

(Seal)

Witness as to Surety

NOTE: Date of Bond must not be prior to date of Contract. If Contractor is Partnership, all partners should execute bond.

IMPORTANT: Surety companies executing Bond must appear on the Treasury Department's most current list (Circular 570 as amended) and be authorized to transact business in the State of Rhode Island.

*Pawtucket Housing Authority
Kennedy Manor Waste Pipe Replacements
Pawtucket, Rhode Island*

NOTICE OF AWARD

*Pawtucket Housing Authority
Kennedy Manor Waste Pipe Replacements
Pawtucket, Rhode Island*

Notice of Award - 1

NOTICE OF AWARD

TO: _____

**PROJECT DESCRIPTION: PAWTUCKET HOUSING AUTHORITY KENNEDY MANOR
WASTE PIPE REPLACEMENTS PROJECT**

The OWNER has considered the BID submitted by you for the above-referenced WORK in response to its invitation for Bids.

You are hereby notified that your BID has been accepted for items in the amounts shown in the Bid Schedule.

You are required by the Information for Bidders to execute the Agreement and furnish the required CONTRACTOR'S PERFORMANCE BOND, PAYMENT BOND and certificates of insurance within ten (10) calendar days from the date of this Notice to you.

If you fail to execute said Agreement and to furnish said BONDS within ten (10) days from the date of this NOTICE, said OWNER will be entitled to consider all your rights arising out of the OWNER'S acceptance of your BID as abandoned and as a forfeiture of your BID BOND. The OWNER will be entitled to such other rights as may be granted by law.

You are required to return an acknowledged copy of this NOTICE OF AWARD to the OWNER.

Dated this day of _____, 20__.

Pawtucket Housing Authority, Pawtucket, Rhode Island
OWNER

BY: _____

TITLE: _____

ACCEPTANCE OF NOTICE

Receipt of the above NOTICE OF AWARD is hereby acknowledged by this the ____ day of _____, 20__.

BY: _____

TITLE: _____

NOTICE TO PROCEED

*Pawtucket Housing Authority
Kennedy Manor Waste Pipe Replacements
Pawtucket, Rhode Island*

Notice to Proceed - 1

NOTICE TO PROCEED

TO: _____

DATE:

PROJECT: Kennedy Manor Waste Pipe Replacements

You are hereby notified to commence WORK in accordance with the Agreement dated _____, on or before _____, and you are to complete the work by, _____, 20__.

Pawtucket Housing Authority, Pawtucket, Rhode Island
OWNER

BY: _____

TITLE: _____

ACCEPTANCE OF NOTICE

Receipt of the above NOTICE TO PROCEED IS
Hereby acknowledged by:

Contractor's Company Name Printed

this the _____ day of _____, 20__.

By: _____

Title: _____

PREVAILING WAGE RATES

*Pawtucket Housing Authority
Kennedy Manor Waste Pipe Replacements
Pawtucket, Rhode Island*

Prevailing Wage Rates - 1

PREVAILING WAGE RATES

Attention of the bidders is particularly called to the requirements as to conditions of employment to be observed and minimum wage rates to be paid under the Contract. The minimum wages for a day's work paid to craftsmen, and laborers shall be not less than the customary and prevailing rate of wages for a day's work in the locality where the work is undertaken. Such a schedule of wages has been established on a minimum hourly basis and is on file in the office of the State Department of Labor

The State of Rhode Island Department of Labor, Division of Professional Regulation General Decision Modification document current as of the bid posting date for this Project, is an integral part of the Bid Documents for use in fulfilling prevailing wage rate requirements. A copy is available on the web site of the State of Rhode Island Department of Labor & Training website.

The Department of Labor & Training Website:

<http://www.dlt.ri.gov>

END OF DOCUMENT

"General Decision Number: RI20240001 09/20/2024

Superseded General Decision Number: RI20230001

State: Rhode Island

Construction Types: Building, Heavy (Heavy and Marine) and Highway

Counties: Rhode Island Statewide.

BUILDING CONSTRUCTION PROJECTS (does not include residential construction consisting of single family homes and apartments up to and including 4 stories) HEAVY, HIGHWAY AND MARINE CONSTRUCTION PROJECTS

Note: Contracts subject to the Davis-Bacon Act are generally required to pay at least the applicable minimum wage rate required under Executive Order 14026 or Executive Order 13658. Please note that these Executive Orders apply to covered contracts entered into by the federal government that are subject to the Davis-Bacon Act itself, but do not apply to contracts subject only to the Davis-Bacon Related Acts, including those set forth at 29 CFR 5.1(a)(1).

If the contract is entered into on or after January 30, 2022, or the contract is renewed or extended (e.g., an option is exercised) on or after January 30, 2022:	. Executive Order 14026 generally applies to the contract. . The contractor must pay all covered workers at least \$17.20 per hour (or the applicable wage rate listed on this wage determination, if it is higher) for all hours spent performing on the contract in 2024.
If the contract was awarded on or between January 1, 2015 and January 29, 2022, and the contract is not renewed or extended on or after January 30, 2022:	. Executive Order 13658 generally applies to the contract. . The contractor must pay all covered workers at least \$12.90 per hour (or the applicable wage rate listed on this wage determination, if it is higher) for all hours spent performing on that contract in 2024.

The applicable Executive Order minimum wage rate will be adjusted annually. If this contract is covered by one of the Executive Orders and a classification considered necessary for performance of work on the contract does not appear on this wage determination, the contractor must still submit a conformance request.

Additional information on contractor requirements and worker protections under the Executive Orders is available at <http://www.dol.gov/whd/govcontracts>.

Modification Number	Publication Date
0	01/05/2024
1	01/12/2024
2	02/23/2024
3	03/08/2024
4	03/22/2024
5	04/05/2024
6	05/24/2024
7	05/31/2024
8	06/14/2024
9	06/21/2024
10	07/05/2024
11	07/12/2024
12	08/23/2024
13	08/30/2024
14	09/20/2024

ASBE0006-006 09/01/2023

	Rates	Fringes
HAZARDOUS MATERIAL HANDLER (Includes preparation, wetting, stripping, removal scrapping, vacuuming, bagging & disposing of all insulation materials, whether they contain asbestos or not, from mechanical systems).....	\$ 48.15	34.84

ASBE0006-008 09/01/2023

	Rates	Fringes
Asbestos Worker/Insulator Includes application of all insulating materials, protective coverings, coatings & finishes to all types of mechanical systems.	\$ 48.15	34.84

BOIL0029-001 01/01/2021

	Rates	Fringes
BOILERMAKER.....	\$ 45.87	29.02

BRRIO003-001 06/01/2022

	Rates	Fringes
Bricklayer, Stonemason, Pointer, Caulker & Cleaner.....	\$ 46.86	29.14

BRRIO003-002 09/01/2022

	Rates	Fringes
Marble Setter, Terrazzo Worker & Tile Setter.....	\$ 46.54	30.34

BRRIO003-003 09/01/2022

Rates	Fringes
-------	---------

Marble, Tile & Terrazzo
 Finisher.....\$ 38.78 29.61

 CARP0330-001 06/03/2024

	Rates	Fringes
CARPENTER (Includes Soft Floor Layer).....	\$ 45.13	30.25
Diver Tender.....	\$ 44.88	30.25
DIVER.....	\$ 57.03	30.25
Piledriver.....	\$ 41.53	29.35
WELDER.....	\$ 44.88	30.25

FOOTNOTES:

When not diving or tending the diver, the diver and diver tender shall receive the piledriver rate. Diver tenders shall receive \$1.00 per hour above the pile driver rate when tending the diver.

Work on free-standing stacks, concrete silos & public utility electrical power houses, which are over 35 ft. in height when constructed: \$.50 per hour additional.

Work on exterior concrete shear wall gang forms, 45 ft. or more above ground elevation or on setback: \$.50 per hour additional.

The designated piledriver, known as the ""monkey"": \$1.00 per hour additional.

 CARP1121-002 01/02/2023

	Rates	Fringes
MILLWRIGHT.....	\$ 41.54	30.73

 ELEC0099-002 06/01/2024

	Rates	Fringes
ELECTRICIAN.....	\$ 52.11	47.25%
Teledata System Installer.....	\$ 39.09	11.02%+15.31

FOOTNOTES:

Work of a hazardous nature, or where the work height is 30 ft. or more from the floor, except when working OSHA-approved lifts: 20% per hour additional.

Work in tunnels below ground level in combined sewer outfall: 20% per hour additional.

 ELEV0039-001 01/01/2024

	Rates	Fringes
ELEVATOR MECHANIC.....	\$ 61.88	37.885+a+b

FOOTNOTES:

a. PAID HOLIDAYS: New Years Day; Memorial Day; Independence Day; Labor Day; Veterans' Day; Thanksgiving Day; the Friday after Thanksgiving Day; and Christmas Day.

b. Employer contributes 8% basic hourly rate for 5 years or more of service of 6% basic hourly rate for 6 months to 5 years of service as vacation pay credit.

 * ENGI0057-001 06/01/2024

	Rates	Fringes
Operating Engineer: (power plants, sewer treatment plants, pumping stations, tunnels, caissons, piers, docks, bridges, wind turbines, subterranean & other marine and heavy construction work)		
GROUP 1.....	\$ 48.05	29.25
GROUP 2.....	\$ 46.05	29.25
GROUP 3.....	\$ 41.67	29.25
GROUP 4.....	\$ 38.82	29.25
GROUP 5.....	\$ 45.10	29.25
GROUP 6.....	\$ 35.90	29.25
GROUP 7.....	\$ 29.90	29.25
GROUP 8.....	\$ 41.75	29.25
GROUP 9.....	\$ 45.67	29.25

a. BOOM LENGTHS, INCLUDING JIBS:

- 150 feet and over + \$ 2.00
- 180 feet and over + \$ 3.00
- 210 feet and over + \$ 4.00
- 240 feet and over + \$ 5.00
- 270 feet and over + \$ 7.00
- 300 feet and over + \$ 8.00
- 350 feet and over + \$ 9.00
- 400 feet and over + \$10.00

a. PAID HOLIDAYS:

New Year's Day, President's Day, Memorial Day, July Fourth, Victory Day, Labor Day, Columbus Day, Veterans Day, Thanksgiving Day, Christmas Day. a: Any employee who works 3 days in the week in which a holiday falls shall be paid for the holiday.

a. FOOTNOTES:

Hazmat work: \$2.00 per hour additional.
 Tunnel/Shaft work: \$5.00 per hour additional.

POWER EQUIPMENT OPERATORS CLASSIFICATIONS

GROUP 1: Cranes, lighters, boom trucks and derricks

GROUP 2: Digging machine, Ross Carrier, locomotive, hoist, elevator, bidwell-type machine, shot & water blasting machine, paver, spreader, graders, front end loader (3 yds. and over), vibratory hammer & vacuum truck, roadheaders, forklifts, economobile type equipment, tunnel boring machines, concrete pump and on site concrete plants.

GROUP 3: Oilers on cranes.

GROUP 4: Oiler on crawler backhoe.

GROUP 5: Bulldozer, bobcats, skid steer loader, tractor, scraper, combination loader backhoe, roller, front end loader (less than 3 yds.), street and mobile-powered sweeper (3-yd. capacity), 8-ft. sweeper minimum 65 HP).

GROUP 6: Well-point installation crew.

GROUP 7: Utility Engineers and Signal Persons

GROUP 8: Heater, concrete mixer, stone crusher, welding machine, generator and light plant, gas and electric driven pump and air compressor.

GROUP 9: Boat & tug operator.

ENGI0057-003 06/01/2024

BUILDING CONSTRUCTION

	Rates	Fringes
Power Equipment Operator		
GROUP 1.....	\$ 47.32	29.90
GROUP 2.....	\$ 45.32	29.90
GROUP 3.....	\$ 45.10	29.90
GROUP 4.....	\$ 41.10	29.90
GROUP 5.....	\$ 37.50	29.90
GROUP 6.....	\$ 38.25	29.90
GROUP 7.....	\$ 43.97	29.90
GROUP 8.....	\$ 41.29	29.90

a. BOOM LENGTHS, INCLUDING JIBS:

- 150 ft. and over: + \$ 2.00
- 180 ft. and over: + \$ 3.00
- 210 ft. and over: + \$ 4.00
- 240 ft. and over: + \$ 5.00
- 270 ft. and over: + \$ 7.00
- 300 ft. and over: + \$ 8.00
- 350 ft. and over: + \$ 9.00
- 400 ft. and over: + \$10.00

a. PAID HOLIDAYS: New Year's Day, President's Day, Memorial Day, July Fourth, Victory Day, Labor Day, Columbus Day, Veterans Day, Thanksgiving Day & Christmas Day. a: Any employee who works 3 days in the week in which a holiday falls shall be paid for the holiday.

a. FOOTNOTE: Hazmat work: \$2.00 per hour additional.
Tunnel/Shaft work: \$5.00 per hour additional.

POWER EQUIPMENT OPERATORS CLASSIFICATIONS

GROUP 1: Cranes, lighters, boom trucks and derricks.

GROUP 2: Digging machine, Ross carrier, locomotive, hoist, elevator, bidwell-type machine, shot & water blasting machine, paver, spreader, front end loader (3 yds. and over), vibratory hammer and vacuum truck

GROUP 3: Telehandler equipment, forklift, concrete pump & on-site concrete plant

GROUP 4: Fireman & oiler on cranes

GROUP 5: Oiler on crawler backhoe

GROUP 6: Bulldozer, skid steer loaders, bobcats, tractor, grader, scraper, combination loader backhoe, roller, front end loader (less than 3 yds.), street and mobile powered sweeper (3 yds. capacity), 8-ft. sweeper (minimum 65 hp)

GROUP 7: Well point installation crew

GROUP 8: Heater, concrete mixer, stone crusher, welding machine, generator for light plant, gas and electric driven pump & air compressor

* ENGI0057-005 05/01/2024

	Rates	Fringes
Power Equipment Operator (highway construction projects; water and sewerline projects which are incidental to highway construction projects; and bridge projects that do not span water)		
GROUP 1.....	\$ 43.20	29.25
GROUP 2.....	\$ 41.20	29.25
GROUP 3.....	\$ 35.90	29.25
GROUP 4.....	\$ 22.50	29.25
GROUP 5.....	\$ 29.90	29.25
GROUP 6.....	\$ 36.48	29.25
GROUP 7.....	\$ 40.18	29.25
GROUP 8.....	\$ 35.45	29.25

a. FOOTNOTE: a. Any employee who works three days in the week in which a holiday falls shall be paid for the holiday.

b. PAID HOLIDAYS: New Year's Day, President's Day, Memorial Day, July Fourth, Victory Day, Labor Day, Columbus Day, Veterans Day, Thanksgiving Day & Christmas Day.

POWER EQUIPMENT OPERATOR CLASSIFICATIONS

GROUP 1: Cranes, pile drivers, lighters, boom trucks, hoists, derricks

GROUP 2: Digging machines, excavators, locomotives, John Henry's, directional drilling machines, cold planers, reclaimers, pavers, spreaders, graders, front-end loaders (3yds & over), vacuum truck, drill/boring machine operators, vermeer saw, water blaster, hydraulic-demolition robot, Ross Carriers, concrete pump operators, asphalt/material transfer machines, rotating telehandlers, SPMT type equipment

GROUP 3: Wellpoint installation and drill/boring machine assistants

GROUP 4: Utility engineers

GROUP 5: Signal persons

GROUP 6: Oilers on cranes and deckhands

GROUP 7: Combination loader / backhoes, front-end loaders (less than 3 yds.), forklift, bulldozers, scrapers, boats, rollers, skid steer loaders (regardless of attachments), street sweepers, mechanics, welders, operators in materials yards, shops and garages

GROUP 8: Gas and electric drive heaters, concrete mixers, light plants, welding machines, pumps and compressors

IRON0037-001 03/16/2024

	Rates	Fringes
IRONWORKER.....	\$ 40.75	32.83

LABO0271-001 12/03/2023

BUILDING CONSTRUCTION

	Rates	Fringes
LABORER		
GROUP 1.....	\$ 37.00	26.90
GROUP 2.....	\$ 37.00	26.90
GROUP 3.....	\$ 37.00	26.90
GROUP 4.....	\$ 37.00	26.90
GROUP 5.....	\$ 39.00	26.90

LABORERS CLASSIFICATIONS

GROUP 1: Laborer, Carpenter Tender, Mason Tender, Cement Finisher Tender, Scaffold Erector, Wrecking Laborer, Asbestos Removal [Non-Mechanical Systems]

GROUP 2: Asphalt Raker, Adzemen, Pipe Trench Bracer, Demolition Burner, Chain Saw Operator, Fence & Guard Rail Erector, Setter of Metal Forms for Roadways, Mortar Mixer, Pipelayer, Riprap & Dry Stonewall Builder, Highway Stone Spreader, Pneumatic Tool Operator, Wagon Drill Operator, Tree Trimmer, Barco-Type Jumping Tamper, Mechanical Grinder Operator

GROUP 3: Pre-Cast Floor & Roof Plank Erectors

GROUP 4: Air Track Operator, Hydraulic & Similar Self-Powered Drill, Block Paver, Rammer, Curb Setter, Powderman & Blaster

GROUP 5: Toxic Waste Remover

LABORERS CLASSIFICATIONS

GROUP 1: Laborer, Carpenter Tender, Mason Tender, Cement Finisher Tender, Scaffold Erector, Wrecking Laborer, Asbestos Removal [Non-Mechanical Systems]

GROUP 2: Asphalt Raker, Adzemen, Pipe Trench Bracer, Demolition Burner, Chain Saw Operator, Fence & Guard Rail Erector, Setter of Metal Forms for Roadways, Mortar Mixer, Pipelayer, Riprap & Dry Stonewall Builder, Highway Stone Spreader, Pneumatic Tool Operator, Wagon Drill Operator, Tree Trimmer, Barco-Type Jumping Tamper, Mechanical Grinder

Operator

GROUP 3: Pre-Cast Floor & Roof Plank Erectors

GROUP 4: Air Track Operator, Hydraulic & Similar Self-Powered Drill, Block Paver, Rammer, Curb Setter, Powderman & Blaster

GROUP 5: Toxic Waste Remover

LAB00271-002 11/27/2022

HEAVY AND HIGHWAY CONSTRUCTION

	Rates	Fringes
LABORER		
COMPRESSED AIR		
Group 1.....	\$ 55.40	24.15
Group 2.....	\$ 52.93	24.15
Group 3.....	\$ 42.45	24.15
FREE AIR		
Group 1.....	\$ 46.00	24.15
Group 2.....	\$ 45.00	24.15
Group 3.....	\$ 42.45	24.15
LABORER		
Group 1.....	\$ 33.05	24.05
Group 2.....	\$ 35.75	24.85
Group 3.....	\$ 36.50	24.85
Group 4.....	\$ 29.00	24.85
Group 5.....	\$ 37.50	24.85
OPEN AIR CAISSON, UNDERPINNING WORK AND BORING CREW		
Bottom Man.....	\$ 41.50	24.15
Top Man & Laborer.....	\$ 35.60	24.15
TEST BORING		
Driller.....	\$ 41.95	24.15
Laborer.....	\$ 41.95	24.15

LABORER CLASSIFICATIONS

GROUP 1: Laborer; Carpenter tender; Cement finisher tender; Wrecking laborer; Asbestos removers [non-mechanical systems]; Plant laborer; Driller in quarries

GROUP 2: Adzeperson; Asphalt raker; Barcotype jumping tamper; Chain saw operators; Concrete and power buggy operator; Concrete saw operator; Demolition burner; Fence and guard rail erector; Highway stone spreader; Laser beam operator; Mechanical grinder operator; Mason tender; Mortar mixer; Pneumatic tool operator; Riprap and dry stonewall builder; Scaffold erector; Setter of metal forms for roadways; Wagon drill operator; Wood chipper operator; Pipelayer; Pipe trench bracer

GROUP 3: Air track drill operator; Hydraulic and similar powered drills; Brick paver; Block paver; Rammer and curb setter; Powderperson and blaster

GROUP 4: Flagger & signaler

GROUP 5: Toxic waste remover

LABORER - COMPRESSED AIR CLASSIFICATIONS

GROUP 1: Mucking machine operator, tunnel laborer, brake person, track person, miner, grout person, lock tender, gauge tender, miner: motor person & all others in compressed air

GROUP 2: Change house attendant, powder watchperson, top person on iron

GROUP 3: Hazardous waste work within the ""HOT"" zone

LABORER - FREE AIR CLASSIFICATIONS

GROUP 1: Grout person - pumps, brake person, track person, form mover & stripper (wood & steel), shaft laborer, laborer topside, outside motorperson, miner, conveyor operator, miner welder, heading motorperson, erecting operator, mucking machine operator, nozzle person, rodperson, safety miner, shaft & tunnel, steel & rodperson, mole nipper, concrete worker, form erector (wood, steel and all accessories), cement finisher (this type of work only), top signal person, bottom person (when heading is 50' from shaft), burner, shield operator and TBM operator

GROUP 2: Change house attendant, powder watchperson

GROUP 3: Hazardous waste work within the ""HOT"" zone

LABORER CLASSIFICATIONS

GROUP 1: Laborer; Carpenter tender; Cement finisher tender; Wrecking laborer; Asbestos removers [non-mechanical systems]; Plant laborer; Driller in quarries

GROUP 2: Adzeperson; Asphalt raker; Barcotype jumping tamper; Chain saw operators; Concrete and power buggy operator; Concrete saw operator; Demolition burner; Fence and guard rail erector; Highway stone spreader; Laser beam operator; Mechanical grinder operator; Mason tender; Mortar mixer; Pneumatic tool operator; Riprap and dry stonewall builder; Scaffold erector; Setter of metal forms for roadways; Wagon drill operator; Wood chipper operator; Pipelayer; Pipe trench bracer

GROUP 3: Air track drill operator; Hydraulic and similar powered drills; Brick paver; Block paver; Rammer and curb setter; Powderperson and blaster

GROUP 4: Flagger & signaler

GROUP 5: Toxic waste remover

LABORER - COMPRESSED AIR CLASSIFICATIONS

GROUP 1: Mucking machine operator, tunnel laborer, brake person, track person, miner, grout person, lock tender, gauge tender, miner: motor person & all others in compressed air

GROUP 2: Change house attendant, powder watchperson, top person on iron

GROUP 3: Hazardous waste work within the ""HOT"" zone

LABORER - FREE AIR CLASSIFICATIONS

GROUP 1: Grout person - pumps, brake person, track person, form mover & stripper (wood & steel), shaft laborer, laborer topside, outside motorperson, miner, conveyor operator, miner welder, heading motorperson, erecting operator, mucking machine operator, nozzle person, rodperson, safety miner, shaft & tunnel, steel & rodperson, mole nipper, concrete worker, form erector (wood, steel and all accessories), cement finisher (this type of work only), top signal person, bottom person (when heading is 50' from shaft), burner, shield operator and TBM operator

GROUP 2: Change house attendant, powder watchperson

GROUP 3: Hazardous waste work within the ""HOT"" zone

 PAIN0011-005 06/01/2024

	Rates	Fringes
PAINTER		
Brush and Roller.....	\$ 38.07	25.80
Epoxy, Tanks, Towers, Swing Stage & Structural Steel.....	\$ 40.07	25.80
Spray, Sand & Water Blasting.....	\$ 41.07	25.80
Taper.....	\$ 38.82	25.80
Wall Coverer.....	\$ 38.57	25.80

 PAIN0011-006 06/01/2024

	Rates	Fringes
GLAZIER.....	\$ 41.63	26.15

FOOTNOTES:

SWING STAGE: \$1.00 per hour additional.

PAID HOLIDAYS: Labor Day & Christmas Day.

 PAIN0011-011 06/01/2024

	Rates	Fringes
Painter (Bridge Work).....	\$ 57.85	26.40

 PAIN0035-008 06/01/2011

	Rates	Fringes
Sign Painter.....	\$ 24.79	13.72

 PLAS0040-001 01/01/2024

BUILDING CONSTRUCTION

	Rates	Fringes
CEMENT MASON/CONCRETE FINISHER...	\$ 43.00	29.10

FOOTNOTE: Cement Mason: Work on free swinging scaffolds under 3 planks width and which is 20 or more feet above ground

and any offset structure: \$.30 per hour additional.

PLAS0040-002 01/01/2024

HEAVY AND HIGHWAY CONSTRUCTION

	Rates	Fringes
CEMENT MASON/CONCRETE FINISHER...	\$ 38.45	25.30

PLAS0040-003 01/01/2024

	Rates	Fringes
PLASTERER.....	\$ 43.65	29.43

PLUM0051-002 08/28/2023

	Rates	Fringes
Plumbers and Pipefitters.....	\$ 50.59	32.75

ROOF0033-004 06/01/2024

	Rates	Fringes
ROOFER.....	\$ 44.80	31.13

SFRI0669-001 04/01/2024

	Rates	Fringes
SPRINKLER FITTER.....	\$ 49.98	32.85

SHEE0017-002 06/01/2024

	Rates	Fringes
Sheet Metal Worker.....	\$ 42.69	38.45

TEAM0251-001 05/01/2024

HEAVY AND HIGHWAY CONSTRUCTION

	Rates	Fringes
TRUCK DRIVER		
GROUP 1.....	\$ 30.71	36.9125+A+B
GROUP 2.....	\$ 30.86	36.9125+A+B
GROUP 3.....	\$ 30.91	36.9125+A+B
GROUP 4.....	\$ 30.96	36.9125+A+B
GROUP 5.....	\$ 31.06	36.9125+A+B
GROUP 6.....	\$ 31.46	36.9125+A+B
GROUP 7.....	\$ 31.66	36.9125+A+B
GROUP 8.....	\$ 31.16	36.9125+A+B
GROUP 9.....	\$ 31.41	36.9125+A+B
GROUP 10.....	\$ 31.21	36.9125+A+B

FOOTNOTES:

A. Paid Holidays: New Year's Day, Memorial Day, Independence Day, Labor Day, Thanksgiving Day and Christmas Day, plus Presidents' Day, Columbus Day, Veteran's Day & V-J Day, providing the employee has worked at least one day in the

calendar week in which the holiday falls.

B. Employee who has been on the payroll for 1 year or more but less than 5 years and has worked 150 Days during the last year of employment shall receive 1 week's paid vacation; 5 to 10 years - 2 weeks' paid vacation; 10 or more years - 3 week's paid vacation.

C. Employees on the seniority list shall be paid a one hundred dollar (\$100.00) bonus for every four hundred (400) hours worked, up to a maximum of five hundred dollars (\$500.00)

All drivers working on a defined hazard material job site shall be paid a premium of \$2.00 per hour over applicable rate.

TRUCK DRIVER CLASSIFICATIONS

GROUP 1: Pick-up trucks, station wagons, & panel trucks

GROUP 2: Two-axle on low beds

GROUP 3: Two-axle dump truck

GROUP 4: Three-axle dump truck

GROUP 5: Four- and five-axle equipment

GROUP 6: Low-bed or boom trailer.

GROUP 7: Trailers when used on a double hook up (pulling 2 trailers)

GROUP 8: Special earth-moving equipment, under 35 tons

GROUP 9: Special earth-moving equipment, 35 tons or over

GROUP 10: Tractor trailer

WELDERS - Receive rate prescribed for craft performing operation to which welding is incidental.

=====
Note: Executive Order (EO) 13706, Establishing Paid Sick Leave for Federal Contractors applies to all contracts subject to the Davis-Bacon Act for which the contract is awarded (and any solicitation was issued) on or after January 1, 2017. If this contract is covered by the EO, the contractor must provide employees with 1 hour of paid sick leave for every 30 hours they work, up to 56 hours of paid sick leave each year. Employees must be permitted to use paid sick leave for their own illness, injury or other health-related needs, including preventive care; to assist a family member (or person who is like family to the employee) who is ill, injured, or has other health-related needs, including preventive care; or for reasons resulting from, or to assist a family member (or person who is like family to the employee) who is a victim of, domestic violence, sexual assault, or stalking. Additional information on contractor requirements and worker protections under the EO is available at <https://www.dol.gov/agencies/whd/government-contracts>.

Unlisted classifications needed for work not included within the scope of the classifications listed may be added after award only as provided in the labor standards contract clauses (29CFR 5.5 (a) (1) (iii)).

The body of each wage determination lists the classification and wage rates that have been found to be prevailing for the cited type(s) of construction in the area covered by the wage determination. The classifications are listed in alphabetical order of ""identifiers"" that indicate whether the particular rate is a union rate (current union negotiated rate for local), a survey rate (weighted average rate) or a union average rate (weighted union average rate).

Union Rate Identifiers

A four letter classification abbreviation identifier enclosed in dotted lines beginning with characters other than ""SU"" or ""UAVG"" denotes that the union classification and rate were prevailing for that classification in the survey. Example: PLUM0198-005 07/01/2014. PLUM is an abbreviation identifier of the union which prevailed in the survey for this classification, which in this example would be Plumbers. 0198 indicates the local union number or district council number where applicable, i.e., Plumbers Local 0198. The next number, 005 in the example, is an internal number used in processing the wage determination. 07/01/2014 is the effective date of the most current negotiated rate, which in this example is July 1, 2014.

Union prevailing wage rates are updated to reflect all rate changes in the collective bargaining agreement (CBA) governing this classification and rate.

Survey Rate Identifiers

Classifications listed under the ""SU"" identifier indicate that no one rate prevailed for this classification in the survey and the published rate is derived by computing a weighted average rate based on all the rates reported in the survey for that classification. As this weighted average rate includes all rates reported in the survey, it may include both union and non-union rates. Example: SULA2012-007 5/13/2014. SU indicates the rates are survey rates based on a weighted average calculation of rates and are not majority rates. LA indicates the State of Louisiana. 2012 is the year of survey on which these classifications and rates are based. The next number, 007 in the example, is an internal number used in producing the wage determination. 5/13/2014 indicates the survey completion date for the classifications and rates under that identifier.

Survey wage rates are not updated and remain in effect until a new survey is conducted.

Union Average Rate Identifiers

Classification(s) listed under the UAVG identifier indicate that no single majority rate prevailed for those classifications; however, 100% of the data reported for the classifications was union data. EXAMPLE: UAVG-OH-0010

08/29/2014. UAVG indicates that the rate is a weighted union average rate. OH indicates the state. The next number, 0010 in the example, is an internal number used in producing the wage determination. 08/29/2014 indicates the survey completion date for the classifications and rates under that identifier.

A UAVG rate will be updated once a year, usually in January of each year, to reflect a weighted average of the current negotiated/CBA rate of the union locals from which the rate is based.

State Adopted Rate Identifiers

Classifications listed under the "SA" identifier indicate that the prevailing wage rate set by a state (or local) government was adopted under 29 C.F.R. 1.3(g)-(h). Example: SAME2023-007 01/03/2024. SA reflects that the rates are state adopted. ME refers to the State of Maine. 2023 is the year during which the state completed the survey on which the listed classifications and rates are based. The next number, 007 in the example, is an internal number used in producing the wage determination. 01/03/2024 reflects the date on which the classifications and rates under the SA identifier took effect under state law in the state from which the rates were adopted.

WAGE DETERMINATION APPEALS PROCESS

1.) Has there been an initial decision in the matter? This can be:

- * an existing published wage determination
- * a survey underlying a wage determination
- * a Wage and Hour Division letter setting forth a position on a wage determination matter
- * a conformance (additional classification and rate) ruling

On survey related matters, initial contact, including requests for summaries of surveys, should be with the Wage and Hour National Office because National Office has responsibility for the Davis-Bacon survey program. If the response from this initial contact is not satisfactory, then the process described in 2.) and 3.) should be followed.

With regard to any other matter not yet ripe for the formal process described here, initial contact should be with the Branch of Construction Wage Determinations. Write to:

Branch of Construction Wage Determinations
Wage and Hour Division
U.S. Department of Labor
200 Constitution Avenue, N.W.
Washington, DC 20210

2.) If the answer to the question in 1.) is yes, then an interested party (those affected by the action) can request review and reconsideration from the Wage and Hour Administrator (See 29 CFR Part 1.8 and 29 CFR Part 7). Write to:

Wage and Hour Administrator
U.S. Department of Labor
200 Constitution Avenue, N.W.
Washington, DC 20210

The request should be accompanied by a full statement of the interested party's position and by any information (wage payment data, project description, area practice material, etc.) that the requestor considers relevant to the issue.

3.) If the decision of the Administrator is not favorable, an interested party may appeal directly to the Administrative Review Board (formerly the Wage Appeals Board). Write to:

Administrative Review Board
U.S. Department of Labor
200 Constitution Avenue, N.W.
Washington, DC 20210

4.) All decisions by the Administrative Review Board are final.

=====

END OF GENERAL DECISION"

HUD DOCUMENTS

*Pawtucket Housing Authority
Kennedy Manor Waste Pipe Replacements
Pawtucket, Rhode Island*

HUD Documents - 1

General Contract Conditions for Small Construction/Development Contracts

U.S. Department of Housing and Urban Development
Office of Public and Indian Housing
OMB Approval No. 2577-0157 (exp. 3/31/2020)

Applicability. The following contract clauses are applicable and must be inserted into small construction/development contracts, greater than \$2,000 but not more than \$150,000.

1. Definitions

Terms used in this form are the same as defined in form HUD-5370

2. Prohibition Against Liens

The Contractor is prohibited from placing a lien on the PHA's property. This prohibition shall apply to all subcontractors at any tier and all materials suppliers. The only liens on the PHA's property shall be the Declaration of Trust or other liens approved by HUD.

3. Disputes

- (a) Except for disputes arising under the **Labor Standards** clauses, all disputes arising under or relating to this contract, including any claims for damages for the alleged breach thereof which are not disposed of by agreement, shall be resolved under this clause.
- (b) All claims by the Contractor shall be made in writing and submitted to the Contracting Officer for a written decision. A claim by the PHA against the Contractor shall be subject to a written decision by the Contracting Officer.
- (c) The Contracting Officer shall, within 30 days after receipt of the request, decide the claim or notify the Contractor of the date by which the decision will be made.
- (d) The Contracting Officer's decision shall be final unless the Contractor (1) appeals in writing to a higher level in the PHA in accordance with the PHA's policy and procedures, (2) refers the appeal to an independent mediator or arbitrator, or (3) files suit in a court of competent jurisdiction. Such appeal must be made within 30 days after receipt of the Contracting Officer's decision.
- (e) The Contractor shall proceed diligently with performance of this contract, pending final resolution of any request for relief, claim, appeal, or action arising under or relating to the contract, and comply with any decision of the Contracting Officer.

4. Default

- (a) If the Contractor refuses or fails to prosecute the work, or any separable part thereof, with the diligence that will insure its completion within the time specified in this contract, or any extension thereof, or fails to complete said work within this time, the Contracting Officer may, by written notice to the Contractor, terminate the right to proceed with the work (or separable part of the work) that has been delayed. In the event, the PHA may take over the work and complete it by contract or otherwise, and may take possession of and use any materials, equipment, and plant on the work site necessary for completing the work. The Contractor and its sureties shall be liable for any damage to the PHA resulting from the Contractor's refusal or failure to complete the work within the specified time, whether or not the Contractor's right to proceed with the work is terminated. This liability includes any increased costs incurred by the PHA in completing the work.

- (b) The Contractor's right to proceed shall not be terminated or the Contractor charged with damages under this clause if –
 - (1) The delay in completing the work arises from unforeseeable causes beyond the control and without the fault or negligence of the Contractor; and
 - (2) The Contractor, within 10 days from the beginning of such delay notifies the Contracting Officer in writing of the causes of delay. The Contracting Officer shall ascertain the facts and the extent of the delay. If, in the judgment of the Contracting Officer, the findings of Fact warrant such action, time for completing the work shall be extended by written modification to the contract. The findings of the Contracting Officer shall be reduced to a written decision which shall be subject to the provisions of the **Disputes** clause of this contract.
- (c) If, after termination of the Contractor's right to proceed, it is determined that the Contractor was not in default, or that the delay was excusable, the rights and obligation of the parties will be the same as if the termination had been for convenience of the PHA.

5. Termination for Convenience

- (a) The Contracting Officer may terminate this contract in whole, or in part, whenever the Contracting Officer determines that such termination is in the best interest of the PHA. Any such termination shall be effected by delivery to the Contractor of a Notice of Termination specifying the extent to which the performance of the work under the contract is terminated, and the date upon which such termination becomes effective.
- (b) If the performance of the work is terminated, either in whole or in part, the PHA shall be liable to the Contractor for reasonable and proper costs resulting from such termination upon the receipt by the PHA of a properly presented claim setting out in detail: (1) the total cost of the work performed to date of termination less the total amount of contract payments made to the Contractor; (2) the cost (including reasonable profit) of settling and paying claims under subcontracts and material orders for work performed and materials and supplies delivered to the site, payment for which has not been made by the PHA to the Contractor or by the Contractor to the subcontractor or supplier; (3) the cost of preserving and protecting the work already performed until the PHA or assignee takes possession thereof or assumes responsibility therefore; (4) the actual or estimated cost of legal and accounting services reasonably necessary to prepare and present the termination claim to the PHA; and (5) an amount constituting a reasonable profit on the value of the work performed by the Contractor.
- (c) The Contracting Officer will act on the Contractor's claim within days (60 days unless otherwise indicated) of receipt of the Contractor's claim.
- (d) Any disputes with regard to this clause are expressly made subject to the provisions of the Disputes clause of this contract.

6. Insurance

- (a) Before commencing work, the Contractor and each subcontractor shall furnish the PHA with certificates of insurance showing the following insurance is in force and will insure all operations under the Contract:

(1) Workers' Compensation, in accordance with state or Territorial Workers' Compensation laws.

(2) Commercial General Liability with a combined single limit for bodily injury and property damage of not less than \$ _____ [Contracting Officer insert amount] per occurrence to protect the Contractor and each subcontractor against claims for bodily injury or death and damage to the property of others. This shall cover the use of all equipment, hoists, and vehicles on the site(s) not covered by Automobile Liability under (3) below. If the Contractor has a "claims-made" policy, then the following additional requirements apply: the policy must provide a "retroactive date" which must be on or before the execution date of the Contract; and the extended reporting period may not be less than five years following the completion date of the Contract.

(3) Automobile Liability on owned and non-owned motor vehicles used on the site(s) or in connection therewith for a combined single limit for bodily injury and property damage of not less than \$ _____ [Contracting Officer insert amount] per occurrence.

(b) Before commencing work, the Contractor shall furnish the PHA with a certificate of insurance evidencing that Builder's Risk (fire and extended coverage) Insurance on all work in place and/or materials stored at the building site(s), including foundations and building equipment, is in force. The Builder's Risk Insurance shall be for the benefit of the Contractor and the PHA as their interests may appear and each shall be named in the policy or policies as an insured. The Contractor in installing equipment supplied by the PHA shall carry insurance on such equipment from the time the Contractor takes possession thereof until the Contract work is accepted by the PHA. The Builder's Risk Insurance need not be carried on excavations, piers, footings, or foundations until such time as work on the superstructure is started. It need not be carried on landscape work. Policies shall furnish coverage at all times for the full cash value of all completed construction, as well as materials in place and/or stored at the site(s), whether or not partial payment has been made by the PHA. The Contractor may terminate this insurance on buildings as of the date taken over for occupancy by the PHA. The Contractor is not required to carry Builder's Risk Insurance for modernization work which does not involve structural alterations or additions and where the PHA's existing fire and extended coverage policy can be endorsed to include such work.

(c) All insurance shall be carried with companies which are financially responsible and admitted to do business in the State in which the project is located. If any such insurance is due to expire during the construction period, the Contractor (including subcontractors, as applicable) shall not permit the coverage to lapse and shall furnish evidence of coverage to the Contracting Officer. All certificates of insurance, as evidence of coverage, shall provide that no coverage may be canceled or non-renewed by the insurance company until at least 30 days prior written notice has been given to the Contracting Officer.

7. Contract Modifications

(a) Only the Contracting Officer has authority to modify any term or condition of this contract. Any contract modification shall be authorized in writing.

(b) The Contracting Officer may modify the contract unilaterally (1) pursuant to a specific authorization stated in a contract clause (e.g., Changes); or (2) for administrative matters which

do not change the rights or responsibilities of the parties (e.g., change in the PHA address). All other contract modifications shall be in the form of supplemental agreements signed by the Contractor and the Contracting Officer.

(c) When a proposed modification requires the approval of HUD prior to its issuance (e.g., a change order that exceeds the PHA's approved threshold), such modification shall not be effective until the required approval is received by the PHA.

8. Changes

(a) The Contracting Officer may, at any time, without notice to the sureties, by written order designated or indicated to be a change order, make changes in the work within the general scope of the contract including changes:

(1) In the specifications (including drawings and designs);

(2) In the method or manner of performance of the work;

(3) PHA-furnished facilities, equipment, materials, services, or site; or,

(4) Directing the acceleration in the performance of the work.

(b) Any other written order or oral order (which, as used in this paragraph (b), includes direction, instruction, interpretation, or determination) from the Contracting Officer that causes a change shall be treated as a change order under this clause; provided, that the Contractor gives the Contracting Officer written notice stating (1) the date, circumstances and source of the order and (2) that the Contractor regards the order as a change order.

(c) Except as provided in this clause, no order, statement or conduct of the Contracting Officer shall be treated as a change under this clause or entitle the Contractor to an equitable adjustment.

(d) If any change under this clause causes an increase or decrease in the Contractor's cost of, or the time required for the performance of any part of the work under this contract, whether or not changed by any such order, the Contracting Officer shall make an equitable adjustment and modify the contract in writing. However, except for a adjustment based on defective specifications, no proposal for any change under paragraph (b) above shall be allowed for any costs incurred more than 20 days (5 days for oral orders) before the Contractor gives written notice as required. In the case of defective specifications for which the PHA is responsible, the equitable adjustment shall include any increased cost reasonably incurred by the Contractor in attempting to comply with the defective specifications.

(e) The Contractor must assert its right to an adjustment under this clause within 30 days after (1) receipt of a written change order under paragraph (a) of this clause, or (2) the furnishing of a written notice under paragraph (b) of this clause, by submitting a written statement describing the general nature and the amount of the proposal. If the facts justify it, the Contracting Officer may extend the period for submission. The proposal may be included in the notice required under paragraph (b) above. No proposal by the Contractor for an equitable adjustment shall be allowed if asserted after final payment under this contract.

(f) The Contractor's written proposal for equitable adjustment shall be submitted in the form of a lump sum proposal supported with an itemized breakdown of all increases and decreases in the contract in at least the following details:

(1) Direct Costs. Materials (list individual items, the quantity and unit cost of each, and the aggregate cost); Transportation and delivery costs associated with materials; Labor

- qualifications for each; and the name and location of the person(s) taking applications for each of the positions; and the anticipated date the work shall begin.
- (d) The contractor agrees to include this section 3 clause in every subcontract subject to compliance with regulations in 24 CFR Part 135, and agrees to take appropriate action, as provided in an applicable provision of the subcontract or in this section 3 clause, upon a finding that the subcontractor is in violation of the regulations in 24 CFR Part 135. The contractor will not subcontract with any subcontractor where the contractor has notice or knowledge that the subcontractor has been found in violation of the regulations in 24 CFR Part 135.
 - (e) The contractor will certify that any vacant employment positions, including training positions, that are filled (1) after the contractor is selected but before the contract is executed, and (2) with persons other than those to whom the regulations of 24 CFR Part 135 require employment opportunities to be directed, were not filled to circumvent the contractor's obligations under 24 CFR Part 135.
 - (f) Noncompliance with HUD's regulations in 24 CFR Part 135 may result in sanctions, termination of this contract for default, and debarment or suspension from future HUD assisted contracts.

14. Labor Standards - Davis-Bacon and Related Acts

(a) Minimum Wages.

(1) All laborers and mechanics employed under this contract in the construction or development of the project(s) involved will be paid unconditionally and not less often than once a week, and without subsequent deduction or rebate on any account (except such payroll deductions as are permitted by regulations issued by the Secretary of Labor under the Copeland Act (29 CFR Part 3)), the full amount of wages and bona fide fringe benefits (or cash equivalents thereof) due at time of payment computed at rates not less than those contained in the wage determination of the Secretary of Labor which is attached hereto and made a part hereof, regardless of any contractual relationship which may be alleged to exist between the Contractor and such laborers and mechanics. Contributions made or costs reasonably anticipated for bona fide fringe benefits under Section 1(b)(2) of the Davis-Bacon Act on behalf of laborers or mechanics are considered wages paid to such laborers or mechanics, subject to the provisions of 29 CFR 5.5(a)(1)(iv); also, regular contributions made or costs incurred for more than a weekly period (but not less often than quarterly) under plans, funds, or programs which cover the regular weekly period, are deemed to be constructively made or incurred during such weekly period. Such laborers and mechanics shall be paid the appropriate wage rate and fringe benefits in the wage determination for the classification of work actually performed, without regard to skill, except as provided in 29 CFR 5.5(a)(4). Laborers or mechanics performing work in more than one classification may be compensated at the rate specified for each classification for the time actually worked therein; provided, that the employer's payroll records accurately set forth the time spent in each classification in which work is performed. The wage determination (including any additional classification and wage rates conformed under 29 CFR 5.5(a)(1)(ii) and the Davis-Bacon poster (WII-1321) shall be posted at all times by the Contractor and its subcontractors at the site of the work in

a prominent and accessible place where it can be easily seen by the workers.

- (2) (i) Any class of laborers or mechanics, including helpers, which is not listed in the wage determination and which is to be employed under the contract shall be classified in conformance with the wage determination. HUD shall approve an additional classification and wage rate and fringe benefits therefor only when all the following criteria have been met:
 - (a) The work to be performed by the classification requested is not performed by a classification in the wage determination; and
 - (b) The classification is utilized in the area by the construction industry; and
 - (c) The proposed wage rate, including any bona fide fringe benefits, bears a reasonable relationship to the wage rates contained in the wage determination.
- (ii) If the Contractor and the laborers and mechanics to be employed in the classification (if known), or their representatives, and HUD or its designee agree on the classification and wage rate (including the amount designated for fringe benefits where appropriate), a report of the action shall be sent by HUD or its designee to the Administrator of the Wage and Hour Division, Employee Standards Administration, U.S. Department of Labor, Washington, DC 20210. The Administrator, or an authorized representative, will approve, modify, or disapprove every additional classification action within 30 days of receipt and so advise HUD or its designee or will notify HUD or its designee within the 30-day period that additional time is necessary.
- (iii) In the event the Contractor, the laborers or mechanics to be employed in the classification or their representatives, and HUD or its designee do not agree on the proposed classification and wage rate (including the amount designated for fringe benefits, where appropriate), HUD or its designee shall refer the questions, including the views of all interested parties and the recommendation of HUD or its designee, to the Administrator of the Wage and Hour Division for determination. The Administrator, or an authorized representative, will issue a determination within 30 days of receipt and so advise HUD or its designee or will notify HUD or its designee within the 30-day period that additional time is necessary.
- (iv) The wage rate (including fringe benefits where appropriate) determined pursuant to subparagraphs (a)(2)(ii) or (iii) of this clause shall be paid to all workers performing work in the classification under this contract from the first day on which work is performed in the classification.
- (3) Whenever the minimum wage rate prescribed in the contract for a class of laborers or mechanics includes a fringe benefit which is not expressed as an hourly rate, the Contractor shall either pay the benefit as stated in the wage determination or shall pay another bona fide fringe benefit or an hourly cash equivalent thereof.
- (4) If the Contractor does not make payments to a trustee or other third person, the Contractor may consider as part

of the wages of any laborer or mechanic the amount of any costs reasonably anticipated in providing bona fide fringe benefits under a plan or program; *provided*, that the Secretary of Labor has found, upon the written request of the Contractor, that the applicable standards of the Davis-Bacon Act have been met. The Secretary of Labor may require the Contractor to set aside in a separate account assets for the meeting of obligations under the plan or program.

(b) **Withholding of Funds.** HUD or its designee shall, upon its own action or upon written request of an authorized representative of the Department of Labor, withhold or cause to be withheld from the Contractor under this contract or any other Federal contract with the same prime Contractor, or any other Federally-assisted contract subject to Davis-Bacon prevailing wage requirements, which is held by the same prime Contractor, so much of the accrued payments or advances as may be considered necessary to pay laborers and mechanics, including apprentices, trainees, and helpers, employed by the Contractor or any subcontractor the full amount of wages required by the contract. In the event of failure to pay any laborer or mechanic, including any apprentice, trainee, or helper, employed or working in the construction or development of the project, all or part of the wages required by the contract, HUD or its designee may, after written notice to the Contractor, take such action as may be necessary to cause the suspension of any further payment, advance, or guarantee of funds until such violations have ceased. HUD or its designee may, after written notice to the Contractor, disburse such amounts withheld for and on account of the Contractor or subcontractor to the respective employees to whom they are due.

(c) **Payrolls and Basic Records.**

(1) Payrolls and basic records relating thereto shall be maintained by the Contractor during the course of the work and preserved for a period of three years thereafter for all laborers and mechanics working in the construction or development of the project. Such records shall contain the name, address, and social security number of each such worker, his or her correct classification, hourly rates of wages paid (including rates of contributions or costs anticipated for bona fide fringe benefits or cash equivalents thereof of the types described in section 1(b)(2)(B) of the Davis-Bacon Act), daily and weekly number of hours worked, deductions made, and actual wages paid. Whenever the Secretary of Labor has found, under 29 CFR 5.5(a)(1)(iv), that the wages of any laborer or mechanic include the amount of costs reasonably anticipated in providing benefits under a plan or program described in section 1(b)(2)(B) of the Davis-Bacon Act, the Contractor shall maintain records which show that the commitment to provide such benefits is enforceable, that the plan or program is financially responsible, and that the plan or program has been communicated in writing to the laborers or mechanics affected, and records which show the costs anticipated or the actual cost incurred in providing such benefits. Contractors employing apprentices or trainees under approved programs shall maintain written evidence of

the registration of apprenticeship programs and certification of trainee programs, the registration of the apprentices and trainees, and the ratios and wage rates prescribed in the applicable programs.

- (2) (i) The Contractor shall submit weekly for each week in which any contract work is performed a copy of all payrolls to the Contracting Officer for transmission to HUD or its designee. The payrolls submitted shall set out accurately and completely all of the information required to be maintained under subparagraph (c)(1) of this clause. This information may be submitted in any form desired. Optional Form WH-347 (Federal Stock Number 029-005-00014-1) is available for this purpose and may be purchased from the Superintendent of Documents, U.S. Government Printing Office, Washington, D.C. 20402. The prime Contractor is responsible for the submission of copies of payrolls by all subcontractors. (Approved by the Office of Management and Budget under OMB Control Number 1214-0149.)
- (ii) Each payroll submitted shall be accompanied by a "Statement of Compliance," signed by the contractor or subcontractor or his or her agent who pays or supervises the payment of the persons employed under the contract and shall certify the following:
- (A) That the payroll for the payroll period contains the information required to be maintained under paragraph (c)(1) of this clause and that such information is correct and complete;
- (B) That each laborer or mechanic (including each helper, apprentice, and trainee) employed on the contract during the payroll period has been paid the full weekly wages earned, without rebate, either directly or indirectly, and that no deductions have been made either directly or indirectly from the full wages earned, other than permissible deductions as set forth in 29 CFR Part 3; and
- (C) That each laborer or mechanic has been paid not less than the applicable wage rates and fringe benefits or cash equivalents for the classification of work performed, as specified in the applicable wage determination incorporated into the contract.
- (iii) The weekly submission of a properly executed certification set forth on the reverse side of Optional Form WH-347 shall satisfy the requirements for submission of the "Statement of Compliance" required by subparagraph (c)(2)(ii) of this clause.
- (iv) The falsification of any of the above certifications may subject the Contractor or subcontractor to civil or criminal prosecution under Section 1001 of Title 18 and Section 3729 of Title 31 of the United States Code.
- (3) The Contractor or subcontractor shall make the records required under subparagraph (c)(1) available for inspection, copying, or transcription by authorized representatives of HUD or its designee, the Contracting Officer, or the Department of Labor and shall permit such representatives to interview employees during working hours on the job. If the Contractor or subcontractor fails to submit the required records or to make them available, HUD or its designee may, after written notice to the Contractor, take such action as may be necessary to cause the suspension of any further payment, advance, or guarantee of funds. Furthermore, failure to submit the required records upon request or to make such records available may be grounds for debarment action pursuant to 29 CFR 5.12.

(d) Apprentices. Apprentices will be permitted to work at less than the predetermined rate for the work they performed when they are employed pursuant to and individually registered in a bona fide apprenticeship program registered with the U.S.

Department of Labor, Employment and Training Administration, Office of Apprenticeship Training, Employer and Labor Services (OATELS), or with a State Apprenticeship Agency recognized by OATELS, or if a person is employed in his or her first 90 days of probationary employment as an apprentice in such an apprenticeship program, who is not individually registered in the program, but who has been certified by OATELS or a State Apprenticeship Agency (where appropriate) to be eligible for probationary employment as an apprentice.

The allowable ratio of apprentices to journeymen on the job site in any craft classification shall not be greater than the ratio permitted to the Contractor as to the entire work force under the registered program. Any worker listed on a payroll at an apprentice wage rate, who is not registered or otherwise employed as stated in this paragraph, shall be paid not less than the applicable wage rate on the wage determination for the classification of work actually performed. In addition, any apprentice performing work on the job site in excess of the ratio permitted under the registered program shall be paid not less than the applicable wage rate on the wage determination for the work actually performed. Where a contractor is performing construction on a project in a locality other than that in which its program is registered, the ratios and wage rates (expressed in percentages of the journeyman's hourly rate) specified in the Contractor's or subcontractor's registered program shall be observed. Every apprentice must be paid at not less than the rate specified in the registered program for the apprentice's level of progress, expressed as a percentage of the journeyman hourly rate specified in the applicable wage determination. Apprentices shall be paid fringe benefits in accordance with the provisions of the apprenticeship program. If the apprenticeship program does not specify fringe benefits, apprentices must be paid the full amount of fringe benefits listed on the wage determination for the applicable classification. If the Administrator of the Wage and Hour Division determines that a different practice prevails for the applicable apprentice classification, fringes shall be paid in accordance with that determination. In the event OATELS, or a State Apprenticeship Agency recognized by OATELS, withdraws approval of an apprenticeship program, the Contractor will no longer be permitted to utilize apprentices at less than the applicable predetermined rate for the work performed until an acceptable program is approved.

(e) Trainees. Except as provided in 29 CFR 5.16, trainees will not be permitted to work at less than the predetermined rate for the work performed unless they are employed pursuant to and individually registered in a program which has received prior approval, evidenced by formal certification by the U.S. Department of Labor, Employment and Training Administration. The ratio of trainees to journeymen on the job site shall not be greater than permitted under the plan approved by the Employment and Training Administration. Every trainee must be paid at not less than the rate specified in the approved program for the trainee's level of progress, expressed as a percentage of the journeyman hourly rate

specified in the applicable wage determination. Trainees shall be paid fringe benefits in accordance with the provisions of the trainee program. If the trainee program does not mention fringe benefits, trainees shall be paid the full amount of fringe benefits listed in the wage determination unless the Administrator of the Wage and Hour Division determines that there is an apprenticeship program associated with the corresponding journeyman wage rate in the wage determination which provides for less than full fringe benefits for apprentices. Any employee listed on the payroll at a trainee rate who is not registered and participating in a training plan approved by the Employment and Training Administration shall be paid not less than the applicable wage rate in the wage determination for the classification of work actually performed. In addition, any trainee performing work on the job site in excess of the ratio permitted under the registered program shall be paid not less than the applicable wage rate in the wage determination for the work actually performed. In the event the Employment and Training Administration withdraws approval of a training program, the Contractor will no longer be permitted to utilize trainees at less than the applicable predetermined rate for the work performed until an acceptable program is approved.

- (f) Equal Employment Opportunity. The utilization of apprentices, trainees, and journeymen under this clause shall be in conformity with the equal employment opportunity requirements of Executive Order 11246, as amended, and 29 CFR Part 30.
- (g) Compliance with Copeland Act Requirements. The Contractor shall comply with the requirements of 29 CFR Part 3, which are hereby incorporated by reference in this contract.
- (h) Contract Termination; Debarment. A breach of the labor standards clauses in this contract may be grounds for termination of the contract and for debarment as a Contractor and a subcontractor as provided in 29 CFR 5.12.
- (i) Compliance with Davis-Bacon and related Act Requirements. All rulings and interpretations of the Davis-Bacon and related Acts contained in 29 CFR Parts 1, 3, and 5 are herein incorporated by reference in this contract.
- (j) Disputes Concerning Labor Standards. Disputes arising out of the labor standards provisions of this clause shall not be subject to the general disputes clause of this contract. Such disputes shall be resolved in accordance with the procedures of the Department of Labor set forth in 29 CFR Parts 5, 6, and 7. Disputes within the meaning of this clause include disputes between the Contractor (or any of its subcontractors) and the PHA, HUD, the U.S. Department of Labor, or the employees or their representatives.
- (k) Certification of Eligibility.
 - (1) By entering into this contract, the Contractor certifies that neither it (nor he or she) nor any person or firm who has an interest in the Contractor's firm is a person or firm ineligible to be awarded contracts by the United States Government by virtue of section 3(a) of the Davis-Bacon Act or 29 CFR 5.12(a)(1).
 - (2) No part of this contract shall be subcontracted to any person or firm ineligible for award of a United States Government

contract by virtue of section 3(a) of the Davis-Bacon Act or 29 CFR 5.12(a)(1).

(3) The penalty for making false statements is prescribed in the U. S. Criminal Code, 18 U.S.C. 1001.

(l) **Subcontracts.** The Contractor or subcontractor shall insert in any subcontracts all the provisions contained in this clause, and such other clauses as HUD or its designee may by appropriate instructions require, and also a clause requiring the subcontractors to include these provisions in any lower tier subcontracts. The prime Contractor shall be responsible for the compliance by any subcontractor or lower tier subcontractor with all these provisions.

(m) **Non-Federal Prevailing Wage Rates.** Any prevailing wage rate (including basic hourly rate and any fringe benefits), determined under State law to be prevailing, with respect to any employee in any trade or position employed under the contract, is inapplicable to the contract and shall not be enforced against the Contractor or any subcontractor, with respect to employees engaged under the contract whenever such non-Federal prevailing wage rate exceeds:

- (i) the applicable wage rate determined by the Secretary of Labor pursuant to the Davis-Bacon Act (40 U.S.C. 3141 et seq.) to be prevailing in the locality with respect to such trade;
- (ii) an applicable apprentice wage rate based thereon specified in an apprenticeship program registered with the U.S. Department of Labor (DOL) or a DOL-recognized State Apprenticeship Agency; or
- (iii) an applicable trainee wage rate based thereon specified in a DOL-certified trainee program.

Previous Participation Certification

U.S. Department of Housing and Urban Development
Office of Housing/Federal Housing Commissioner

U.S. Department of Agriculture
Farmers Home Administration

OMB Approval No. 2502-0118
(exp11/30/2012)

Part I To be completed by Principals of Multifamily Projects. See Instructions Reason for Submitting Certification

For HUD HQ/FmHA use only

1. Agency Name and City where the application is filed

2. Project Name, Project Number, City and Zip Code contained in the application

3. Loan or Contract Amount

4. Number of Units or Beds

5. Section of Act

6. Type of Project (check one)

Existing

Rehabilitation

Proposed (New)

List of all proposed Principal Participants and attach organization chart for all organizations.

7. Names and Addresses of All Known Principals and Affiliates (people, businesses & organizations) proposing to participate in the project described above. (list names alphabetically; last, first, middle initial)

8. Role of Each Principal in Project

9. Expected % Ownership Interest in Project

10. Social Security or IRS Employer Number

Certifications: I (meaning the individual who signs as well as the corporations, partnerships or other parties listed above who certify) hereby apply to HUD or USDA FmHA, as the case maybe, for approval to participate as a principal in the role and project listed above based upon my following previous participation record and this Certification. Verify that neither you nor any of your principals or affiliates have ever been found to be in noncompliance with any applicable fair housing and civil rights requirements in 24 CFR 5.105 (a). If you or any of your principals or affiliates have been found to be in noncompliance with any such requirements, attach a signed statement explaining the relevant facts, circumstances, and resolution, if any.

I certify that all the statements made by me are true, complete and correct to the best of my knowledge and belief and are made in good faith, including the data contained in Schedule A and Exhibits signed by me and attached to this form. **Warning:** HUD will prosecute false claims and statements. Conviction may result in criminal and/or civil penalties. (18 U.S.C. 1001, 1010, 1012; 31U.S.C. 3729, 3802)

I further certify that:

1. Schedule A contains a listing of every assisted or

insured project of HUD, USDA FmHA and State and local government housing finance agencies in which I have been or am now a principal.

2. For the period beginning 10 years prior to the date of this certification, and except as shown by me on the certification.

a. No mortgage on a project listed by me has ever been in default, assigned to the Government or foreclosed, nor has mortgage relief by the mortgagee been given;

b. I have not experienced defaults or noncompliances under any Conventional Contract or Turnkey Contract of Sale in connection with a public housing project;

c. To the best of my knowledge, there are no unresolved findings raised as a result of HUD audits, management reviews or other Governmental investigations concerning me or my projects;

d. There has not been a suspension or termination of payments under any HUD assistance contract in which I have had a legal or beneficial interest;

e. I have not been convicted of a felony and am not presently, to my knowledge, the subject of a

complaint or indictment charging a felony. (A felony is defined as any offense punishable by imprisonment for a term exceeding one year, but does not include any offense classified as a misdemeanor under the laws of a State and punishable by imprisonment of two years or less);

f. I have not been suspended, debarred or otherwise restricted by any Department or Agency of the Federal Government or of a State Government from doing business with such Department or Agency.

g. I have not defaulted on an obligation covered by a surety or performance bond and have not been the subject of a claim under an employee fidelity bond.

3. All the names of the parties, known to me to be principals in this project(s) in which I propose to participate, are listed above.

4. I am not a HUD/FmHA employee or a member of a HUD/FmHA employee's immediate household as defined in Standards of Ethical Conduct for Employees of the Executive Branch in 5C.F.R. Part 2635 (57 FR 35006) and HUD's Standard of Conduct in 24 C.F.R. Part 0 and USDA's Standard of Conduct in 7 C.F.R. Part 0 Subpart B.

5. I am not a principal participant in an assisted or insured project as of this date on which construction has stopped for a period in excess of 20 days or which has been substantially completed for more than 90 days and documents for closing, including final cost certification have not been filed with HUD or FmHA

6. To my knowledge I have not been found by HUD or FmHA to be in noncompliance with any applicable fair housing and civil rights requirements in 24 CFR 5.105(a).

7. I am not a Member of Congress or a Resident Commissioner nor otherwise prohibited or limited by law from contacting with the Government of the United States of America.

8. Statements above (if any) to which I cannot certify have been deleted by striking through the words with a pen. I have initialed each deletion (if any) and have attached a true and accurate signed statement (if applicable) to explain the facts and circumstances which I think helps to qualify me as a responsible principal for participation in this project.

Typed or Printed Name of Principal	Signature of Principal	Certification Date (mm/dd/yyyy)	Area Code and Telephone No.

This form was prepared by (Please print name)

Area Code and Telephone No.

Schedule A: List of Previous Projects and Section 8 Contracts. By my name below is the complete list of my previous projects and my participation history as a principal; in Multifamily Housing programs of HUD/FmHA, State, and Local Housing Finance Agencies. **Note:** Read and follow the instruction sheet carefully. Abbreviate where possible. Make full disclosure. Add extra sheets if you need more space. Double check for accuracy. If you have no previous projects write, by your name, **"No previous participation, First Experience."**

1. List each Principal's Name (list in alphabetical order, last name first)	2. List Previous Projects (give the I.D. number, project name, city location, & government agency involved if other than HUD)	3. List Principals' Role(s) (indicate dates participated, and if fee or identity of interest participant)	4. Status of Loan (current, defaulted, assigned, or foreclosed)	5. Was Project ever in Default, during your participation?		6. Last Mgmt. and/or Physical Inspctn Rating and Date
				Yes	No If "Yes," explain	

Part II – For HUD Internal Processing Only

Received and checked by me for accuracy and completeness; recommend approval or transferral to Headquarters as checked below:

Date (mm/dd/yyyy)	Telephone Number and Area Code	<input type="checkbox"/> A. No adverse information; form HUD-2530 approval is recommended.	<input type="checkbox"/> C. Disclosure or Certification problem
Staff	Processing and Control	<input type="checkbox"/> B. Name match in system	<input type="checkbox"/> D. Other, our memorandum is attached.
Supervisor	Director of Housing / Director, Multifamily Division	Approved <input type="checkbox"/> Yes <input type="checkbox"/> No	Date (mm/dd/yyyy)

Instructions for Completing the Previous Participation Certificate, form HUD-2530

Carefully read these instructions and the applicable regulations. A copy of those regulations published at 24 C.F.R. 200.210 to 200.245 can be obtained from the Multifamily Housing Representative at any HUD Office. Type or print neatly in ink when filling out this form. Mark answers in all blocks of the form. If the form is not filled completely, it will delay approval of your application.

Attach extra sheets as you need them. Be sure to indicate "Continued on Attachments" wherever appropriate. Sign each additional page that you attach if it refers to you or your record. If you have many projects to list (20 or more) and expect to be applying frequently for participation in HUD projects, you should consider filing a Master List. See Master List instructions below under "Instructions for Completing Schedule A."

Carefully read the certification before you sign it. Any questions regarding the form or how to complete it can be answered by your HUD Office Multifamily Housing Representative.

Purpose: This form provides HUD with a certified report of all previous participation in HUD multifamily housing projects by those parties making application. The information requested in this form is used by HUD to determine if you meet the standards established to ensure that all principal participants in HUD projects will honor their legal, financial and contractual obligations and are acceptable risks from the underwriting standpoint of an insurer, lender or governmental agency. HUD requires that you certify your record of previous participation in HUD/USDA-FmHA, State and Local Housing Finance Agency projects by completing and signing this form, before your project application or participation can be approved.

HUD approval of your certification is a necessary precondition for your participation in the project and in the capacity that you propose. If you do not file this certification, do not furnish the information requested accurately, or do not meet established standards, HUD will not approve your certification.

Note that approval of your certification does not obligate HUD to approve your project application, and it does not satisfy all other HUD program requirements relative to your qualifications.

Who Must Sign and File Form HUD-2530:

Form HUD-2530 must be completed and signed by all parties applying to become principal participants in HUD multifamily housing projects, including those who have no previous participation. The form must be signed and filed by all principals and their affiliates who propose participating in the HUD project. Use a separate form for each role in the project unless there is an identity of interest.

Principals include all individuals, joint ventures, partnerships, corporations, trusts, non-profit organizations, any other public or private entity, that will participate in the proposed project as a sponsor, owner, prime contractor, turnkey developer, managing agent, nursing home administrator or operator, packager, or consultant. Architects and attorneys who have any interest in the project other than an arms length fee arrangement for professional services are also considered principals by HUD.

In the case of partnerships, all general partners regardless of their percentage interest and limited partners having a 25 percent or more interest in the partnership are considered principals. In the case of public or private corporations or governmental entities, principals include the president, vice president, secretary, treasurer and all other executive officers who are directly responsible to the board of directors, or any equivalent governing body, as well as all directors and each stockholder having a 10 percent or more interest in the corporation.

Affiliates are defined as any person or business concern that directly or indirectly controls the policy of a principal or has the power to do so. A holding or parent corporation would be an example of an affiliate if one of its subsidiaries is a principal.

Exception for Corporations – All principals and affiliates must personally sign the certificate except in the following situation. When a corporation is a principal, all of its officers, directors, trustees and stockholders with 10 percent or more of the common (voting) stock need not sign personally if they all have the same record to report. The officer who is authorized to sign for the corporation or agency will list the names and title of those who elect not to sign. However, any person who has a record of participation in HUD projects that is separate from that of his or her organization must report that activity on this form and sign his or her name. The objective is full disclosure.

Exemptions – The names of the following parties do not need to be listed on form HUD-2530: Public Housing Agencies, tenants, owners of less than five condominium or cooperative units and all others whose interests were acquired by inheritance or court order.

Where and When Form HUD-2530 Must Be Filed: The original of this form must be submitted to the HUD Office where your project application will be processed at the same time you file your initial project application. This form must be filed with applications for projects, or when otherwise required in the situations listed below:

- Projects to be financed with mortgages insured under the National Housing Act (FHA).
- Projects to be financed according to Section 202 of the Housing Act of 1959 (Elderly and Handicapped).
- Projects in which 20 percent or more of the units are to receive a subsidy as described in 24 C.F.R. 200.213.
- Purchase of a project subject to a mortgage insured or held by the Secretary of HUD.
- Purchase of a Secretary-owned project.
- Proposed substitution or addition of a principal, or principal participation in a different capacity from that previously approved for the same project.
- Proposed acquisition by an existing limited partner of an additional interest in a project resulting in a total interest of 25 percent or more, or proposed acquisition by a corporate stockholder of an additional interest in a project resulting in a total interest of 10 percent or more.
- Projects with U.S.D.A., Farmers Home Administration, or with state or local government housing finance agencies that include rental assistance under Section 8 of the Housing Act of 1937. For projects of this type, form HUD-2530 should be filed with the appropriate applications directly to those agencies.

Review of Adverse Determination: If approval of your participation in a HUD project is denied, withheld, or conditionally granted on the basis of your record of previous participation, you will be notified by the HUD Office. You may request reconsideration by the HUD Review Committee. Alternatively, you may request a hearing before a Hearing Officer. Either request must be made in writing within 30 days from your receipt of the notice of determination.

If you do request reconsideration by the Review Committee and the reconsideration results in an adverse determination, you may then request a hearing before a Hearing Officer. The Hearing Officer will issue a report to the Review Committee. You will be notified of the final ruling by certified mail.

Specific Line Instructions:

Reason for submitting this Certification: e.g., refinance, management, change in ownership, transfer of physical assets, etc.

Block 1: Fill in the name of the agency to which you are applying. For example: HUD Office, Farmers Home Administration District office, or the name of a State or local housing finance agency. Below that, fill in the name of the city where the office is located.

Block 2: Fill in the name of the project, such as "Greenwood Apts." If the name has not yet been selected, write "Name unknown." Below that, enter the HUD contract or project identification number, the Farmers Home Administration project number, or the State or local housing finance agency project or contract number. Include **all** project or contract identification numbers that are relevant to the project. Also enter the name of the city in which the project is located, and the ZIP Code of the site location.

Block 3: Fill in the dollar amount requested in the proposed mortgage, or the annual amount of rental assistance requested.

Block 4: Fill in the number of apartment units proposed, such as "40 units." For hospital projects or nursing homes, fill in the number of beds proposed, such as "100 beds."

Block 5: Fill in the section of the Housing Act under which the application is filed.

Block 7: Definitions of all those who are considered principals and affiliates are given above in the section titled "Who Must Sign and File...."

Block 8: Beside the name of each principal, fill in the role that each will perform. The following are possible roles that the principals may perform: Sponsor, Owner, Prime Contractor, Turnkey Developer, Managing Agent, Packager, Consultant, General Partner, Limited Partner (include percentage), Executive Officer, Director, Trustee, Major Stockholder, or Nursing Home Administrator. Beside the name of each affiliate, write the name of the person or firm of affiliation, such as "Affiliate of Smith Construction Co."

Block 9: Fill in the percentage of ownership in the proposed project that each principal is expected to have. Also specify if the participant is a general or limited partner. Beside the name of those parties who will not be owners, write "None."

Block 10: Fill in the Social Security Number or IRS employer number of every party listed, including affiliates.

Instructions for Completing Schedule A:

Be sure that Schedule A is filled-in completely, accurately and the certification is properly dated and signed, because it will serve as a legal record of your previous experience. All Multifamily Housing projects involving HUD/FmHA, and State and local Housing Finance Agencies in which you have previously participated **must** be listed. Applicants are reminded that previous participation pertains to the individual principal within an entity as well as the entity itself. A newly formed company may not have previous participation, but the principals within the company may have had extensive participation and disclosure of that activity is required. To avoid duplication of disclosure, list the project and then the entities or individuals involved in that project. You may use the name or a number code to denote the entity or individual that participated. The number code can then be used in column 3 to denote role.

Column 2 List the project or contract identification of each previous project. **All previous projects must be included or your certification cannot be processed.** Include the name of all projects, the cities in which they are located and the government agency (HUD, USDA-FmHA or State or local housing finance agency) that was involved. At the end of your list of projects, draw a straight line across the page to separate your record of projects from that of others signing this form who have a different record to report.

Column 3 List the role(s) of your participation, dates participated, and if fee or identity of interest with owners.

Column 4 Indicate the current status of the loan. Except for current loans, the date associated with the status is required. Loans under a workout arrangement are considered assigned. An explanation of the circumstances surrounding the status is required for all non-current loans.

Column 5 Explain any project defaults during your participation.

Column 6 Enter the latest Management and/or Physical Inspection Review rating. If either of the ratings are below average, the report issued by HUD is required to be submitted along with the applicant's explanation of the circumstances surrounding the rating.

No Previous Record: Even if you have never participated in a HUD project before, you must complete form HUD-2530. If you have no record of previous projects to list, fill in your name in column 1 of Schedule A, and write across the form by your name – "No previous participation, first experience."

Master List System: If you expect to file this form frequently and you have a long list of previous projects to report on Schedule A, you should consider filing a Master List. By doing so, you will avoid having to list all your previous projects each time you file a new application.

To make a Master List, use form HUD-2530. On page 1, in block 1, enter (in capital letters) the words "Master List." In blocks 2 through 6 enter in "N.A." meaning Not Applicable. Complete blocks 7 through 10.

In the box below the statement of certification, fill in the names of all parties who wish to file a Master List together (type or print neatly). Beside each name, every party must sign the form. In the box titled "Proposed Role," fill in "N.A." Also, fill in the date you sign the form

and provide a telephone number where you can be reached during the day. No determinations will be made on these certificates.

File one copy of the Master List with each HUD Office where you do business and mail one copy to the following address:

**HUD-2530 Master List
Participation and Compliance
Division – Housing
U.S. Department of Housing and
Urban Development
451 Seventh Street, S.W.
Washington, D.C. 20410**

Once you have filed a Master List, you do not need to complete Schedule A when you submit form HUD-2530. Instead, write the name of the participant in column 1 of Schedule A and beside that write "See Master List on file." Also give the date that appears on the Master List that you submitted. Below that, report all changes and additions that have occurred since that date. Be sure to include any mortgage defaults, assignments or foreclosures not listed previously.

If you have withdrawn from a project since the date the Master List was filed, be sure to name the project. Give the project identification number, the month and year your participation began and/or ended.

Certification:

After you have completed all other parts of form HUD-2530, including Schedule A, read the Certification carefully. In the box below the statement of certification, fill in the name of all principals and affiliates (type or print neatly). Beside the name of each principal and affiliate, each party must sign the form, with the exception in some cases of individuals associated with a corporation (see "Exception for Corporations" in the section of the instructions titled "Who Must Sign and File form

HUD-2530"). Beside each signature, fill in the role of each party (the same as shown in block 8). In addition, each person who signs the form should fill in the date that he or she signs, as well as providing a telephone number where he or she can be reached during business hours. By providing a telephone number where you can be reached, you will help to prevent any possible delay caused by mailing and processing time in the event HUD has any questions.

If you cannot certify and sign the certification as it is printed because some statements do not correctly describe your record, use a pen and strike through those parts that differ with your record, then sign and certify to that remaining part which does describe you or your record.

Attach a signed letter, note or an explanation of the items you have struck out on the certification and report the facts of your correct record. Item A(2)(e) relates to felony convictions within the past 10 years. If you have been convicted of a felony within 10 years, strike out all of A(2)(e) on the certificate and attach your statement giving your explanation. A felony conviction will not necessarily cause your participation to be disapproved unless there is a criminal record or other evidence that your previous conduct or method of doing business has been such that your participation in the project would make it an unacceptable risk from the underwriting standpoint of an insurer, lender or governmental agency.

The Department of Housing and Urban Development (HUD) is authorized to collect this information by law (42 U.S.C. 3535(d) and 24 C.F.R. 200.217) and by regulation at 24 CFR 200.210. This information is needed so that principals applying to participate in multifamily programs can become HUD-approved participants. The information you provide will enable HUD to evaluate your record with respect to established standards of performance, responsibility and eligibility. Without prior approval, a principal may not participate in a proposed or existing multifamily project. HUD uses this information to evaluate whether or not principals pose an unsatisfactory underwriting risk. The information is used to evaluate the potential principals and approve only individuals and organizations who will honor their legal, financial and contractual obligations.

Privacy Act Statement: The Housing and Community Development Act of 1987, 42 U.S.C. 3543 requires persons applying for a Federally-insured or guaranteed loan to furnish his/her Social Security Number (SSN). HUD must have your SSN for identification of your records. HUD may use your SSN for automated processing of your records and to make requests for information about you and your previous records with other public agencies and private sector sources. HUD may disclose certain information to Federal, State and local agencies when relevant to civil, criminal, or regulatory investigations and prosecutions. It will not be otherwise disclosed or released outside of HUD, except as required and permitted by law. You must provide all of the information requested in this application, including your SSN.

Public reporting burden for this collection of information is estimated to average 1 hour per response, including the time for reviewing instructions, searching existing data sources, gathering and maintaining the data needed, and completing and reviewing the collection of information. This agency may not collect this information, and you are not required to complete this form, unless it displays a currently valid OMB control number.

A response is mandatory. Failure to provide any of the information will result in your disapproval for participation in this HUD program.

**U.S. Department of Housing and
Urban Development**
Office of Public and Indian Housing

**Instructions to Bidders for Contracts
Public and Indian Housing Programs**

Instructions to Bidders for Contracts

Public and Indian Housing Programs

Table of Contents

Clause	Page
1. Bid Preparation and Submission	1
2. Explanations and Interpretations to Prospective Bidders	1
3. Amendments to Invitations for Bids	1
4. Responsibility of Prospective Contractor	1
5. Late Submissions, Modifications, and Withdrawal of Bids	1
6. Bid Opening	2
7. Service of Protest	2
8. Contract Award	2
9. Bid Guarantee	3
10. Assurance of Completion	3
11. Preconstruction Conference	3
12. Indian Preference Requirements	3

1. Bid Preparation and Submission

(a) Bidders are expected to examine the specifications, drawings, all instructions, and, if applicable, the construction site (see also the contract clause entitled **Site Investigation and Conditions Affecting the Work** of the *General Conditions of the Contract for Construction*). Failure to do so will be at the bidders' risk.

(b) All bids must be submitted on the forms provided by the Public Housing Agency/Indian Housing Authority (PHA/IHA). Bidders shall furnish all the information required by the solicitation. Bids must be signed and the bidder's name typed or printed on the bid sheet and each continuation sheet which requires the entry of information by the bidder. Erasures or other changes must be initialed by the person signing the bid. Bids signed by an agent shall be accompanied by evidence of that agent's authority. (Bidders should retain a copy of their bid for their records.)

(c) Bidders must submit as part of their bid a completed form HUD-5369-A, "Representations, Certifications, and Other Statements of Bidders."

(d) All bid documents shall be sealed in an envelope which shall be clearly marked with the words "Bid Documents," the Invitation for Bids (IFB) number, any project or other identifying number, the bidder's name, and the date and time for receipt of bids.

(e) If this solicitation requires bidding on all items, failure to do so will disqualify the bid. If bidding on all items is not required, bidders should insert the words "No Bid" in the space provided for any item on which no price is submitted.

(f) Unless expressly authorized elsewhere in this solicitation, alternate bids will not be considered.

(g) Unless expressly authorized elsewhere in this solicitation, bids submitted by telegraph or facsimile (fax) machines will not be considered.

(h) If the proposed contract is for a Mutual Help project (as described in 24 CFR Part 905, Subpart E) that involves Mutual Help contributions of work, material, or equipment, supplemental information regarding the bid advertisement is provided as an attachment to this solicitation.

2. Explanations and Interpretations to Prospective Bidders

(a) Any prospective bidder desiring an explanation or interpretation of the solicitation, specifications, drawings, etc., must request it at least 7 days before the scheduled time for bid opening. Requests may be oral or written. Oral requests must be confirmed in writing. The only oral clarifications that will be provided will be those clearly related to solicitation procedures, i.e., not substantive technical information. No other oral explanation or interpretation will be provided. Any information given a prospective bidder concerning this solicitation will be furnished promptly to all other prospective bidders as a written amendment to the solicitation, if that information is necessary in submitting bids, or if the lack of it would be prejudicial to other prospective bidders.

(b) Any information obtained by, or provided to, a bidder other than by formal amendment to the solicitation shall not constitute a change to the solicitation.

3. Amendments to Invitations for Bids

(a) If this solicitation is amended, then all terms and conditions which are not modified remain unchanged.

(b) Bidders shall acknowledge receipt of any amendment to this solicitation (1) by signing and returning the amendment, (2) by identifying the amendment number and date on the bid form, or (3) by letter, telegram, or facsimile, if those methods are authorized in the solicitation. The PHA/IHA must receive acknowledgement by the time and at the place specified for receipt of bids. Bids which fail to acknowledge the bidder's receipt of any amendment will result in the rejection of the bid if the amendment(s) contained information which substantively changed the PHA's/IHA's requirements.

(c) Amendments will be on file in the offices of the PHA/IHA and the Architect at least 7 days before bid opening.

4. Responsibility of Prospective Contractor

(a) The PHA/IHA will award contracts only to responsible prospective contractors who have the ability to perform successfully under the terms and conditions of the proposed contract. In determining the responsibility of a bidder, the PHA/IHA will consider such matters as the bidder's:

- (1) Integrity;
- (2) Compliance with public policy;
- (3) Record of past performance; and
- (4) Financial and technical resources (including construction and technical equipment).

(b) Before a bid is considered for award, the bidder may be requested by the PHA/IHA to submit a statement or other documentation regarding any of the items in paragraph (a) above. Failure by the bidder to provide such additional information shall render the bidder nonresponsible and ineligible for award.

5. Late Submissions, Modifications, and Withdrawal of Bids

(a) Any bid received at the place designated in the solicitation after the exact time specified for receipt will not be considered unless it is received before award is made and it:

(1) Was sent by registered or certified mail not later than the fifth calendar day before the date specified for receipt of offers (e.g., an offer submitted in response to a solicitation requiring receipt of offers by the 20th of the month must have been mailed by the 15th);

(2) Was sent by mail, or if authorized by the solicitation, was sent by telegram or via facsimile, and it is determined by the PHA/IHA that the late receipt was due solely to mishandling by the PHA/IHA after receipt at the PHA/IHA; or

(3) Was sent by U.S. Postal Service Express Mail Next Day Service - Post Office to Addressee, not later than 5:00 p.m. at the place of mailing two working days prior to the date specified for receipt of proposals. The term "working days" excludes weekends and observed holidays.

(b) Any modification or withdrawal of a bid is subject to the same conditions as in paragraph (a) of this provision.

(c) The only acceptable evidence to establish the date of mailing of a late bid, modification, or withdrawal sent either by registered or certified mail is the U.S. or Canadian Postal Service postmark both on the envelope or wrapper and on the original receipt from the U.S. or Canadian Postal Service. Both postmarks must show a legible date or the bid, modification, or withdrawal shall be processed as if mailed late. "Postmark" means a printed, stamped, or otherwise placed impression (exclusive of a postage meter machine impression) that is readily identifiable without further action as having been supplied and affixed by employees of the U.S. or Canadian Postal Service on the date of mailing. Therefore, bidders should request the postal clerk to place a hand cancellation bull's-eye postmark on both the receipt and the envelope or wrapper.

(d) The only acceptable evidence to establish the time of receipt at the PHA/IHA is the time/date stamp of PHA/IHA on the proposal wrapper or other documentary evidence of receipt maintained by the PHA/IHA.

(e) The only acceptable evidence to establish the date of mailing of a late bid, modification, or withdrawal sent by Express Mail Next Day Service-Post Office to Addressee is the date entered by the post office receiving clerk on the "Express Mail Next Day Service-Post Office to Addressee" label and the postmark on both the envelope or wrapper and on the original receipt from the U.S. Postal Service. "Postmark" has the same meaning as defined in paragraph (c) of this provision, excluding postmarks of the Canadian Postal Service. Therefore, bidders should request the postal clerk to place a legible hand cancellation bull's eye postmark on both the receipt and Failure by a bidder to acknowledge receipt of the envelope or wrapper.

(f) Notwithstanding paragraph (a) of this provision, a late modification of an otherwise successful bid that makes its terms more favorable to the PHA/IHA will be considered at any time it is received and may be accepted.

(g) Bids may be withdrawn by written notice, or if authorized by this solicitation, by telegram (including mailgram) or facsimile machine transmission received at any time before the exact time set for opening of bids; provided that written confirmation of telegraphic or facsimile withdrawals over the signature of the bidder is mailed and postmarked prior to the specified bid opening time. A bid may be withdrawn in person by a bidder or its authorized representative if, before the exact time set for opening of bids, the identity of the person requesting withdrawal is established and the person signs a receipt for the bid.

6. Bid Opening

All bids received by the date and time of receipt specified in the solicitation will be publicly opened and read. The time and place of opening will be as specified in the solicitation. Bidders and other interested persons may be present.

7. Service of Protest

(a) Definitions. As used in this provision:

"Interested party" means an actual or prospective bidder whose direct economic interest would be affected by the award of the contract.

"Protest" means a written objection by an interested party to this solicitation or to a proposed or actual award of a contract pursuant to this solicitation.

(b) Protests shall be served on the Contracting Officer by obtaining written and dated acknowledgement from —

[Contracting Officer designate the official or location where a protest may be served on the Contracting Officer]

(c) All protests shall be resolved in accordance with the PHA's/IHA's protest policy and procedures, copies of which are maintained at the PHA/IHA.

8. Contract Award

(a) The PHA/IHA will evaluate bids in response to this solicitation without discussions and will award a contract to the responsible bidder whose bid, conforming to the solicitation, will be most advantageous to the PHA/IHA considering only price and any price-related factors specified in the solicitation.

(b) If the apparent low bid received in response to this solicitation exceeds the PHA's/IHA's available funding for the proposed contract work, the PHA/IHA may either accept separately priced items (see 8(e) below) or use the following procedure to determine contract award. The PHA/IHA shall apply in turn to each bid (proceeding in order from the apparent low bid to the high bid) each of the separately priced bid deductible items, if any, in their priority order set forth in this solicitation. If upon the application of the first deductible item to all initial bids, a new low bid is within the PHA's/IHA's available funding, then award shall be made to that bidder. If no bid is within the available funding amount, then the PHA/IHA shall apply the second deductible item. The PHA/IHA shall continue this process until an evaluated low bid, if any, is within the PHA's/IHA's available funding. If upon the application of all deductibles, no bid is within the PHA's/IHA's available funding, or if the solicitation does not request separately priced deductibles, the PHA/IHA shall follow its written policy and procedures in making any award under this solicitation.

(c) In the case of tie low bids, award shall be made in accordance with the PHA's/IHA's written policy and procedures.

(d) The PHA/IHA may reject any and all bids, except other than the lowest bid (e.g., the apparent low bid is unreasonably low), and waive informalities or minor irregularities in bids received, in accordance with the PHA's/IHA's written policy and procedures.

(e) Unless precluded elsewhere in the solicitation, the PHA/IHA may accept any item or combination of items bid.

(f) The PHA/IHA may reject any bid as nonresponsive if it is materially unbalanced as to the prices for the various items of work to be performed. A bid is materially unbalanced when it is based on prices significantly less than cost for some work and prices which are significantly overstated for other work.

(g) A written award shall be furnished to the successful bidder within the period for acceptance specified in the bid and shall result in a binding contract without further action by either party.

9. Bid Guarantee (applicable to construction and equipment contracts exceeding \$25,000)

All bids must be accompanied by a negotiable bid guarantee which shall not be less than five percent (5%) of the amount of the bid. The bid guarantee may be a certified check, bank draft, U.S. Government Bonds at par value, or a bid bond secured by a surety company acceptable to the U.S. Government and authorized to do business in the state where the work is to be performed. In the case where the work under the contract will be performed on an Indian reservation area, the bid guarantee may also be an irrevocable Letter of Credit (see provision 10, Assurance of Completion, below). Certified checks and bank drafts must be made payable to the order of the PHA/IHA. The bid guarantee shall insure the execution of the contract and the furnishing of a method of assurance of completion by the successful bidder as required by the solicitation. Failure to submit a bid guarantee with the bid shall result in the rejection of the bid. Bid guarantees submitted by unsuccessful bidders will be returned as soon as practicable after bid opening.

10. Assurance of Completion

(a) Unless otherwise provided in State law, the successful bidder shall furnish an assurance of completion prior to the execution of any contract under this solicitation. This assurance may be [Contracting Officer check applicable items] —

[] (1) a performance and payment bond in a penal sum of 100 percent of the contract price; or, as may be required or permitted by State law;

[] (2) separate performance and payment bonds, each for 50 percent or more of the contract price;

[] (3) a 20 percent cash escrow;

[] (4) a 25 percent irrevocable letter of credit; or,

[] (5) an irrevocable letter of credit for 10 percent of the total contract price with a monitoring and disbursements agreement with the IHA (applicable only to contracts awarded by an IHA under the Indian Housing Program).

(b) Bonds must be obtained from guarantee or surety companies acceptable to the U.S. Government and authorized to do business in the state where the work is to be performed. Individual sureties will not be considered. U.S. Treasury Circular Number 570, published annually in the Federal Register, lists companies approved to act as sureties on bonds securing Government contracts, the maximum underwriting limits on each contract bonded, and the States in which the company is licensed to do business. Use of companies listed in this circular is mandatory. Copies of the circular may be downloaded on the U.S. Department of Treasury website <http://www.fms.treas.gov/c570/index.html>, or ordered for a minimum fee by contacting the Government Printing Office at (202) 512-2168.

(c) Each bond shall clearly state the rate of premium and the total amount of premium charged. The current power of attorney for the person who signs for the surety company must be attached to the bond. The effective date of the power of attorney shall not precede the date of the bond. The effective date of the bond shall be on or after the execution date of the contract.

(d) Failure by the successful bidder to obtain the required assurance of completion within the time specified, or within such extended period as the PHA/IHA may grant based upon reasons determined adequate by the PHA/IHA, shall render the bidder ineligible for award. The PHA/IHA may then either award the contract to the next lowest responsible bidder or solicit new bids. The PHA/IHA may retain the ineligible bidder's bid guarantee.

11. Preconstruction Conference (applicable to construction contracts)

After award of a contract under this solicitation and prior to the start of work, the successful bidder will be required to attend a preconstruction conference with representatives of the PHA/IHA and its architect/engineer, and other interested parties convened by the PHA/IHA. The conference will serve to acquaint the participants with the general plan of the construction operation and all other requirements of the contract (e.g., Equal Employment Opportunity, Labor Standards). The PHA/IHA will provide the successful bidder with the date, time, and place of the conference.

12. Indian Preference Requirements (applicable only if this solicitation is for a contract to be performed on a project for an Indian Housing Authority)

(a) HUD has determined that the contract awarded under this solicitation is subject to the requirements of section 7(b) of the Indian Self-Determination and Education Assistance Act (25 U.S.C. 450e(b)). Section 7(b) requires that any contract or subcontract entered into for the benefit of Indians shall require that, to the greatest extent feasible

(1) Preferences and opportunities for training and employment (other than core crew positions; see paragraph (h) below) in connection with the administration of such contracts or subcontracts be given to qualified "Indians." The Act defines "Indians" to mean persons who are members of an Indian tribe and defines "Indian tribe" to mean any Indian tribe, band, nation, or other organized group or community, including any Alaska Native village or regional or village corporation as defined in or established pursuant to the Alaska Native Claims Settlement Act, which is recognized as eligible for the special programs and services provided by the United States to Indians because of their status as Indians; and,

(2) Preference in the award of contracts or subcontracts in connection with the administration of contracts be given to Indian organizations and to Indian-owned economic enterprises, as defined in section 3 of the Indian Financing Act of 1974 (25 U.S.C. 1452). That Act defines "economic enterprise" to mean any Indian-owned commercial, industrial, or business activity established or organized for the purpose of profit, except that the Indian ownership must constitute not less than 51 percent of the enterprise; "Indian organization" to mean the governing body of any Indian tribe or entity established or recognized by such governing body; "Indian" to mean any person who is a member of any tribe, band, group, pueblo, or community which is recognized by the Federal Government as eligible for services from the Bureau of Indian Affairs and any "Native" as defined in the Alaska Native Claims Settlement Act; and Indian "tribe" to mean any Indian tribe, band, group, pueblo, or community including Native villages and Native groups (including

corporations organized by Kenai, Juneau, Sitka, and Kodiak) as defined in the Alaska Native Claims Settlement Act, which is recognized by the Federal Government as eligible for services from the Bureau of Indian Affairs.

(b) (1) The successful Contractor under this solicitation shall comply with the requirements of this provision in awarding all subcontracts under the contract and in providing training and employment opportunities.

(2) A finding by the IHA that the contractor, either (i) awarded a subcontract without using the procedure required by the IHA, (ii) falsely represented that subcontracts would be awarded to Indian enterprises or organizations; or, (iii) failed to comply with the contractor's employment and training preference bid statement shall be grounds for termination of the contract or for the assessment of penalties or other remedies.

(c) If specified elsewhere in this solicitation, the IHA may restrict the solicitation to qualified Indian-owned enterprises and Indian organizations. If two or more (or a greater number as specified elsewhere in the solicitation) qualified Indian-owned enterprises or organizations submit responsive bids, award shall be made to the qualified enterprise or organization with the lowest responsive bid. If fewer than the minimum required number of qualified Indian-owned enterprises or organizations submit responsive bids, the IHA shall reject all bids and readvertise the solicitation in accordance with paragraph (d) below.

(d) If the IHA prefers not to restrict the solicitation as described in paragraph (c) above, or if after having restricted a solicitation an insufficient number of qualified Indian enterprises or organizations submit bids, the IHA may advertise for bids from non-Indian as well as Indian-owned enterprises and Indian organizations. Award shall be made to the qualified Indian enterprise or organization with the lowest responsive bid if that bid is -

(1) Within the maximum HUD-approved budget amount established for the specific project or activity for which bids are being solicited; and

(2) No more than the percentage specified in 24 CFR 905.175(c) higher than the total bid price of the lowest responsive bid from any qualified bidder. If no responsive bid by a qualified Indian-owned economic enterprise or organization is within the stated range of the total bid price of the lowest responsive bid from any qualified enterprise, award shall be made to the bidder with the lowest bid.

(e) Bidders seeking to qualify for preference in contracting or subcontracting shall submit proof of Indian ownership with their bids. Proof of Indian ownership shall include but not be limited to:

(1) Certification by a tribe or other evidence that the bidder is an Indian. The IHA shall accept the certification of a tribe that an individual is a member.

(2) Evidence such as stock ownership, structure, management, control, financing and salary or profit sharing arrangements of the enterprise.

(f) (1) All bidders must submit with their bids a statement describing how they will provide Indian preference in the award of subcontracts. The specific requirements of that statement and the factors to be used by the IHA in determining the statement's adequacy are included as an attachment to this solicitation. Any bid that fails to include the required statement shall be rejected as nonresponsive. The IHA may require that comparable statements be provided by subcontractors to the successful Contractor, and may require the Contractor to reject any bid or proposal by a subcontractor that fails to include the statement.

(2) Bidders and prospective subcontractors shall submit a certification (supported by credible evidence) to the IHA in any instance where the bidder or subcontractor believes it is infeasible to provide Indian preference in subcontracting. The acceptance or rejection by the IHA of the certification shall be final. Rejection shall disqualify the bid from further consideration.

(g) All bidders must submit with their bids a statement detailing their employment and training opportunities and their plans to provide preference to Indians in implementing the contract; and the number or percentage of Indians anticipated to be employed and trained. Comparable statements from all proposed subcontractors must be submitted. The criteria to be used by the IHA in determining the statement(s)'s adequacy are included as an attachment to this solicitation. Any bid that fails to include the required statement(s), or that includes a statement that does not meet minimum standards required by the IHA shall be rejected as nonresponsive.

(h) Core crew employees. A core crew employee is an individual who is a bona fide employee of the contractor at the time the bid is submitted; or an individual who was not employed by the bidder at the time the bid was submitted, but who is regularly employed by the bidder in a supervisory or other key skilled position when work is available. Bidders shall submit with their bids a list of all core crew employees.

(i) Preference in contracting, subcontracting, employment, and training shall apply not only on-site, on the reservation, or within the IHA's jurisdiction, but also to contracts with firms that operate outside these areas (e.g., employment in modular or manufactured housing construction facilities).

(j) Bidders should contact the IHA to determine if any additional local preference requirements are applicable to this solicitation.

(k) The IHA does does not [Contracting Officer check applicable box] maintain lists of Indian-owned economic enterprises and Indian organizations by specialty (e.g., plumbing, electrical, foundations), which are available to bidders to assist them in meeting their responsibility to provide preference in connection with the administration of contracts and subcontracts.

**U.S. Department of Housing
and Urban Development**
Office of Public and Indian Housing

**Representations, Certifications,
and Other Statements of Bidders**
Public and Indian Housing Programs

Representations, Certifications, and Other Statements of Bidders

Public and Indian Housing Programs

Table of Contents

Clause	Page
1. Certificate of Independent Price Determination	1
2. Contingent Fee Representation and Agreement	1
3. Certification and Disclosure Regarding Payments to Influence Certain Federal Transactions	1
4. Organizational Conflicts of Interest Certification	2
5. Bidder's Certification of Eligibility	2
6. Minimum Bid Acceptance Period	2
7. Small, Minority, Women-Owned Business Concern Representation	2
8. Indian-Owned Economic Enterprise and Indian Organization Representation	2
9. Certification of Eligibility Under the Davis-Bacon Act	3
10. Certification of Nonsegregated Facilities	3
11. Clean Air and Water Certification	3
12. Previous Participation Certificate	3
13. Bidder's Signature	3

1. Certificate of Independent Price Determination

(a) The bidder certifies that--

(1) The prices in this bid have been arrived at independently, without, for the purpose of restricting competition, any consultation, communication, or agreement with any other bidder or competitor relating to (i) those prices, (ii) the intention to submit a bid, or (iii) the methods or factors used to calculate the prices offered;

(2) The prices in this bid have not been and will not be knowingly disclosed by the bidder, directly or indirectly, to any other bidder or competitor before bid opening (in the case of a sealed bid solicitation) or contract award (in the case of a competitive proposal solicitation) unless otherwise required by law; and

(3) No attempt has been made or will be made by the bidder to induce any other concern to submit or not to submit a bid for the purpose of restricting competition.

(b) Each signature on the bid is considered to be a certification by the signatory that the signatory--

(1) Is the person in the bidder's organization responsible for determining the prices being offered in this bid or proposal, and that the signatory has not participated and will not participate in any action contrary to subparagraphs (a)(1) through (a)(3) above; or

(2) (i) Has been authorized, in writing, to act as agent for the following principals in certifying that those principals have not participated, and will not participate in any action contrary to subparagraphs (a)(1) through (a)(3) above.

[insert full name of person(s) in the bidder's organization responsible for determining the prices offered in this bid or proposal, and the title of his or her position in the bidder's organization];

(ii) As an authorized agent, does certify that the principals named in subdivision (b)(2)(i) above have not participated, and will not participate, in any action contrary to subparagraphs (a)(1) through (a)(3) above; and

(iii) As an agent, has not personally participated, and will not participate in any action contrary to subparagraphs (a)(1) through (a)(3) above.

(c) If the bidder deletes or modifies subparagraph (a)2 above, the bidder must furnish with its bid a signed statement setting forth in detail the circumstances of the disclosure.

[] [Contracting Officer check if following paragraph is applicable]

(d) Non-collusive affidavit. (applicable to contracts for construction and equipment exceeding \$50,000)

(1) Each bidder shall execute, in the form provided by the PHA/IHA, an affidavit to the effect that he/she has not colluded with any other person, firm or corporation in regard to any bid submitted in response to this solicitation. If the successful bidder did not submit the affidavit with his/her bid, he/she must submit it within three (3) working days of bid opening. Failure to submit the affidavit by that date may render the bid nonresponsive. No contract award will be made without a properly executed affidavit.

(2) A fully executed "Non-collusive Affidavit" is, is not included with the bid.

2. Contingent Fee Representation and Agreement

(a) Definitions. As used in this provision:

"Bona fide employee" means a person, employed by a bidder and subject to the bidder's supervision and control as to time, place, and manner of performance, who neither exerts, nor proposes to exert improper influence to solicit or obtain contracts nor holds out as being able to obtain any contract(s) through improper influence.

"Improper influence" means any influence that induces or tends to induce a PHA/IHA employee or officer to give consideration or to act regarding a PHA/IHA contract on any basis other than the merits of the matter.

(b) The bidder represents and certifies as part of its bid that, except for full-time bona fide employees working solely for the bidder, the bidder:

(1) has, has not employed or retained any person or company to solicit or obtain this contract; and

(2) has, has not paid or agreed to pay to any person or company employed or retained to solicit or obtain this contract any commission, percentage, brokerage, or other fee contingent upon or resulting from the award of this contract.

(c) If the answer to either (a)(1) or (a)(2) above is affirmative, the bidder shall make an immediate and full written disclosure to the PHA/IHA Contracting Officer.

(d) Any misrepresentation by the bidder shall give the PHA/IHA the right to (1) terminate the contract; (2) at its discretion, deduct from contract payments the amount of any commission, percentage, brokerage, or other contingent fee; or (3) take other remedy pursuant to the contract.

3. Certification and Disclosure Regarding Payments to Influence Certain Federal Transactions (applicable to contracts exceeding \$100,000)

(a) The definitions and prohibitions contained in Section 1352 of title 31, United States Code, are hereby incorporated by reference in paragraph (b) of this certification.

(b) The bidder, by signing its bid, hereby certifies to the best of his or her knowledge and belief as of December 23, 1989 that:

(1) No Federal appropriated funds have been paid or will be paid to any person for influencing or attempting to influence an officer or employee of any agency, a Member of Congress, an officer or employee of Congress, or an employee of a Member of Congress on his or her behalf in connection with the awarding of a contract resulting from this solicitation;

(2) If any funds other than Federal appropriated funds (including profit or fee received under a covered Federal transaction) have been paid, or will be paid, to any person for influencing or attempting to influence an officer or employee of any agency, a Member of Congress, an officer or employee of Congress, or an employee of a Member of Congress on his or her behalf in connection with this solicitation, the bidder shall complete and submit, with its bid, OMB standard form LLL, "Disclosure of Lobbying Activities;" and

(3) He or she will include the language of this certification in all subcontracts at any tier and require that all recipients of subcontract awards in excess of \$100,000 shall certify and disclose accordingly.

(c) Submission of this certification and disclosure is a prerequisite for making or entering into this contract imposed by section 1352, title 31, United States Code. Any person who makes an expenditure prohibited under this provision or who fails to file or amend the disclosure form to be filed or amended by this provision, shall be subject to a civil penalty of not less than \$10,000, and not more than \$100,000, for each such failure.

(d) Indian tribes (except those chartered by States) and Indian organizations as defined in section 4 of the Indian Self-Determination and Education Assistance Act (25 U.S.C. 450B) are exempt from the requirements of this provision.

4. Organizational Conflicts of Interest Certification

The bidder certifies that to the best of its knowledge and belief and except as otherwise disclosed, he or she does not have any organizational conflict of interest which is defined as a situation in which the nature of work to be performed under this proposed contract and the bidder's organizational, financial, contractual, or other interests may, without some restriction on future activities:

- (a) Result in an unfair competitive advantage to the bidder; or,
 - (b) Impair the bidder's objectivity in performing the contract work.
- In the absence of any actual or apparent conflict, I hereby certify that to the best of my knowledge and belief, no actual or apparent conflict of interest exists with regard to my possible performance of this procurement.

5. Bidder's Certification of Eligibility

(a) By the submission of this bid, the bidder certifies that to the best of its knowledge and belief, neither it, nor any person or firm which has an interest in the bidder's firm, nor any of the bidder's subcontractors, is ineligible to:

(1) Be awarded contracts by any agency of the United States Government, HUD, or the State in which this contract is to be performed; or,

(2) Participate in HUD programs pursuant to 24 CFR Part 24.

(b) The certification in paragraph (a) above is a material representation of fact upon which reliance was placed when making award. If it is later determined that the bidder knowingly rendered an erroneous certification, the contract may be terminated for default, and the bidder may be debarred or suspended from participation in HUD programs and other Federal contract programs.

6. Minimum Bid Acceptance Period

(a) "Acceptance period," as used in this provision, means the number of calendar days available to the PHA/IHA for awarding a contract from the date specified in this solicitation for receipt of bids.

(b) This provision supersedes any language pertaining to the acceptance period that may appear elsewhere in this solicitation.

(c) The PHA/IHA requires a minimum acceptance period of [Contracting Officer insert time period] calendar days.

(d) In the space provided immediately below, bidders may specify a longer acceptance period than the PHA's/IHA's minimum requirement. The bidder allows the following acceptance period: calendar days.

(e) A bid allowing less than the PHA's/IHA's minimum acceptance period will be rejected.

(f) The bidder agrees to execute all that it has undertaken to do, in compliance with its bid, if that bid is accepted in writing within (1) the acceptance period stated in paragraph (c) above or (2) any longer acceptance period stated in paragraph (d) above.

7. Small, Minority, Women-Owned Business Concern Representation

The bidder represents and certifies as part of its bid/ offer that it --

(a) is, is not a small business concern. "Small business concern," as used in this provision, means a concern, including its affiliates, that is independently owned and operated, not dominant in the field of operation in which it is bidding, and qualified as a small business under the criteria and size standards in 13 CFR 121.

(b) is, is not a women-owned business enterprise. "Women-owned business enterprise," as used in this provision, means a business that is at least 51 percent owned by a woman or women who are U.S. citizens and who also control and operate the business.

(c) is, is not a minority business enterprise. "Minority business enterprise," as used in this provision, means a business which is at least 51 percent owned or controlled by one or more minority group members or, in the case of a publicly owned business, at least 51 percent of its voting stock is owned by one or more minority group members, and whose management and daily operations are controlled by one or more such individuals. For the purpose of this definition, minority group members are:

(Check the block applicable to you)

- | | |
|---------------------------------------------|---------------------------------------------------|
| <input type="checkbox"/> Black Americans | <input type="checkbox"/> Asian Pacific Americans |
| <input type="checkbox"/> Hispanic Americans | <input type="checkbox"/> Asian Indian Americans |
| <input type="checkbox"/> Native Americans | <input type="checkbox"/> Hasidic Jewish Americans |

8. Indian-Owned Economic Enterprise and Indian Organization Representation (applicable only if this solicitation is for a contract to be performed on a project for an Indian Housing Authority)

The bidder represents and certifies that it:

(a) is, is not an Indian-owned economic enterprise. "Economic enterprise," as used in this provision, means any commercial, industrial, or business activity established or organized for the purpose of profit, which is at least 51 percent Indian owned. "Indian," as used in this provision, means any person who is a member of any tribe, band, group, pueblo, or community which is recognized by the Federal Government as eligible for services from the Bureau of Indian Affairs and any "Native" as defined in the Alaska Native Claims Settlement Act.

(b) is, is not an Indian organization. "Indian organization," as used in this provision, means the governing body of any Indian tribe or entity established or recognized by such governing body. Indian "tribe" means any Indian tribe, band, group, pueblo, or

community including Native villages and Native groups (including corporations organized by Kenai, Juneau, Sitka, and Kodiak) as defined in the Alaska Native Claims Settlement Act, which is recognized by the Federal Government as eligible for services from the Bureau of Indian Affairs.

9. Certification of Eligibility Under the Davis-Bacon Act (applicable to construction contracts exceeding \$2,000)

(a) By the submission of this bid, the bidder certifies that neither it nor any person or firm who has an interest in the bidder's firm is a person or firm ineligible to be awarded contracts by the United States Government by virtue of section 3(a) of the Davis-Bacon Act or 29 CFR 5.12(a)(1).

(b) No part of the contract resulting from this solicitation shall be subcontracted to any person or firm ineligible to be awarded contracts by the United States Government by virtue of section 3(a) of the Davis-Bacon Act or 29 CFR 5.12(a)(1).

(c) The penalty for making false statements is prescribed in the U. S. Criminal Code, 18 U.S.C. 1001.

10. Certification of Nonsegregated Facilities (applicable to contracts exceeding \$10,000)

(a) The bidder's attention is called to the clause entitled **Equal Employment Opportunity** of the General Conditions of the Contract for Construction.

(b) "Segregated facilities," as used in this provision, means any waiting rooms, work areas, rest rooms and wash rooms, restaurants and other eating areas, time clocks, locker rooms and other storage or dressing areas, parking lots, drinking fountains, recreation or entertainment areas, transportation, and housing facilities provided for employees, that are segregated by explicit directive or are in fact segregated on the basis of race, color, religion, or national origin because of habit, local custom, or otherwise.

(c) By the submission of this bid, the bidder certifies that it does not and will not maintain or provide for its employees any segregated facilities at any of its establishments, and that it does not and will not permit its employees to perform their services at any location under its control where segregated facilities are maintained. The bidder agrees that a breach of this certification is a violation of the Equal Employment Opportunity clause in the contract.

(d) The bidder further agrees that (except where it has obtained identical certifications from proposed subcontractors for specific time periods) prior to entering into subcontracts which exceed \$10,000 and are not exempt from the requirements of the Equal Employment Opportunity clause, it will:

- (1) Obtain identical certifications from the proposed subcontractors;
- (2) Retain the certifications in its files; and
- (3) Forward the following notice to the proposed subcontractors (except if the proposed subcontractors have submitted identical certifications for specific time periods):

Notice to Prospective Subcontractors of Requirement for Certifications of Nonsegregated Facilities

A Certification of Nonsegregated Facilities must be submitted before the award of a subcontract exceeding \$10,000 which is not exempt from the provisions of the Equal Employment Opportunity clause of the prime contract. The certification may be submitted either for each subcontract or for all subcontracts during a period (i.e., quarterly, semiannually, or annually).

Note: The penalty for making false statements in bids is prescribed in 18 U.S.C. 1001.

11. Clean Air and Water Certification (applicable to contracts exceeding \$100,000)

The bidder certifies that:

(a) Any facility to be used in the performance of this contract is, is not listed on the Environmental Protection Agency List of Violating Facilities:

(b) The bidder will immediately notify the PHA/IHA Contracting Officer, before award, of the receipt of any communication from the Administrator, or a designee, of the Environmental Protection Agency, indicating that any facility that the bidder proposes to use for the performance of the contract is under consideration to be listed on the EPA List of Violating Facilities; and,

(c) The bidder will include a certification substantially the same as this certification, including this paragraph (c), in every nonexempt subcontract.

12. Previous Participation Certificate (applicable to construction and equipment contracts exceeding \$50,000)

(a) The bidder shall complete and submit with his/her bid the Form HUD-2530, "Previous Participation Certificate." If the successful bidder does not submit the certificate with his/her bid, he/she must submit it within three (3) working days of bid opening. Failure to submit the certificate by that date may render the bid nonresponsive. No contract award will be made without a properly executed certificate.

(b) A fully executed "Previous Participation Certificate" is, is not included with the bid.

13. Bidder's Signature

The bidder hereby certifies that the information contained in these certifications and representations is accurate, complete, and current.

(Signature and Date)

(Typed or Printed Name)

(Title)

(Company Name)

(Company Address)

FORM OF NON-COLLUSIVE AFFIDAVIT

A F F I D A V I T

(Firm Submitting Proposal)

State of _____) ss

Country of _____)

_____, being first duly sworn, deposes and says:

That he is _____ (A partner or officer of the firm of, etc.)
the party making the foregoing proposal, that such proposal is genuine and not collusive or sham; that said person has not colluded, conspired, connived or agreed, directly or indirectly with any person, to put in a sham proposal or to refrain from submitting a proposal, and has not in any manner, directly or indirectly, sought by agreement or collusion, or communication or conference, with any person, to fix the proposal price or affidavit or any other firm submitting a proposal, or to fix any overhead, profit or cost element of said proposal price, or of that of any other firm submitting a proposal, or to secure any advantage against the _____ (LHA) _____ or any person interested in the proposed contract; and that all statements in said proposal are true.

Signature of:

Authorized Individual if Proposal is

Submitted as an Individual, Partnership,

Corporation, etc.

Subscribed and sworn to before me

this _____ day of _____, 20____

My commission expires _____, 20____

Section 3 Clause

A. The work to be performed under this contract is subject to the requirements of section 3 of the Housing and Urban Development Act of 1968, as amended, 12 U.S.C. 1701u (Section 3). The purpose of Section 3 is to ensure that employment and other economic opportunities generated by HUD assistance or HUD-assisted projects covered by Section 3, shall, to the greatest extent feasible, be directed to low- and very low-income persons, particularly persons who are recipients of HUD assistance for housing.

B. The parties to this contract agree to comply with HUD's regulations in 24 CFR part 135, which implement Section 3. As evidenced by their execution of this contract, the parties to this contract certify that they are under no contractual or other impediment that would prevent them from complying with the part 135 regulations.

C. The contractor agrees to send to each labor organization or representative or workers with which the contractor has a collective bargaining agreement or other understanding, if any, a notice advising the labor organization or workers' representative of the contractor's commitments under this Section 3 clause, and will post copies of the notice in conspicuous places at the work site where both employees and applicants for training and employment positions can see the notice. The notice shall describe the Section 3 preference, shall set forth minimum number and job titles subject to hire, availability of apprenticeship and training positions, the qualifications for each; and the name and location of the person(s) taking applications for each of the positions; and the anticipated date the work shall begin.

D. The contractor agrees to include this Section 3 clause in every subcontract subject to compliance with regulations in 24 CFR part 135, and agrees to take appropriate action, as provided in an applicable provision of the subcontract or in this Section 3 clause, upon a finding that the subcontractor is in violation of the regulations in 24 CFR part 135. The contractor will not subcontract with any subcontractor where the contractor has notice or knowledge that the subcontractor has been found in violation of the regulations in 24 CFR part 135.

E. The contractor will certify that any vacant employment positions, including training positions, that are filled (1) after the contractor is selected but before the contract is executed, and (2) with persons other than those to whom the regulations of 24 CFR part 135 require employment opportunities to be directed, were not filled to circumvent the contractor's obligations under 24 CFR part 135.

F. Noncompliance with HUD's regulations in 24 CFR part 135 may result in sanctions, termination of this contract for default, and debarment or suspension from future HUD assisted contracts.

G. With respect to work performed in connection with Section 3 covered Indian housing assistance, section 7(b) of the Indian Self-Determination and Education Assistance Act (25 U.S.C. 450e) also applies to the work to be performed under this contract. Section 7(b) requires that to the greatest extent feasible (i) preference and opportunities for training and employment shall be given to Indians, and (ii) preference in the award of contracts and subcontracts shall be given to Indian organizations and Indian-owned Economic Enterprises. Parties to this contract that are subject to the provisions of Section 3 to the maximum extent feasible, but not in derogation of compliance with section 7(b).

**Record of Employee Interview
Instructions****U.S. Department of Housing
and Urban Development
Office of Labor Relations**OMB Approval No. 2501-0009
(exp. 10/31/2010)InstructionsGeneral:

This form is to be used by HUD and local agency staff for recording information gathered during on-site interviews with laborers and mechanics employed on projects subject to Federal prevailing wage requirements. Typically, the staff that will conduct on-site interviews and use this form are HUD staff and fee construction inspectors, HUD Labor Relations staff, and local agency labor standards contract monitors.

Information recorded on the form HUD-11 is evaluated for general compliance and compared to certified payroll reports submitted by the respective employer. The comparison tests the veracity of the payroll reports and may be critical to the successful conclusion of enforcement actions in the event of labor standards violations. The thoroughness and accuracy of the information gathered during interviews is crucial.

Note that the interview itself and the information collected on the form HUD-11 are considered confidential. Interviews should be conducted individually and privately. All laborers and mechanics employed on the job site must be made available for interview at the interviewer's request. The employee's participation, however, is voluntary. Interviews shall be conducted in a manner and place that are conducive to the purposes of the interview and that cause the least inconvenience to the employer(s) and the employee(s).

Completing the form HUD-11

Items 1a - 1c: Self-explanatory

Items 2a - 2d: Enter the employee's full name, a telephone number where the employee can be reached, and the employee's home address. Many construction workers use a temporary address in the locality of the project and have a more permanent address elsewhere from which mail may be forwarded to them. Obtain a more permanent address, if available. Ask the employee for a form of identification (e.g., driver's license) to verify their name.

Items 3a - 4c: Enter the employee's responses. Ask the employee whether they have a pay stub with them; if so, determine whether the pay stub is consistent with the information provided by the employee.

Items 5 - 7: Be certain that the employee's responses are specific. For example, job classification (#5) must identify the trade involved (e.g., Carpenter, Electrician, Plumber) - responses such as "journeyman" or "mechanic" are not helpful for our purposes.

Items 8 - 12b: Self-explanatory

Items 13 - 15c: These items represent some of the most important information that can be gathered while conducting on-site interviews. Please be specific about the duties you observed the employee performing. It may be easiest to make these observations before initiating the interview. Please record any comments or remarks that may be helpful. For example, if the employee interviewed was working with a crew, how many workers were in the crew? Was the employee evasive?

The level of specificity that is warranted is directly related to the extent to which interview(s) or other observations indicate that there may be violations present. If interviews indicate that there may be underpayments involving a particular trade(s), the interviewer is encouraged to interview as many workers in that trade(s) that are available.

Items 16 - 17b: The information on the form HUD-11 may be reviewed for general compliance, initially. For example, are the job classification and wage rate stated by the employee compatible with the classifications and wage rates on the applicable wage decision? Are the duties observed by the interviewer consistent with the job classification?

Once the corresponding certified payroll reports are received, the information on the HUD-11 shall be compared to the payroll reports. Any discrepancies noted between the HUD-11 information and that on the payroll report shall be noted in item 16, Remarks. If discrepancies are noted, follow-up actions to resolve the discrepancies must be taken.

Record of Employee Interview

U.S. Department of Housing and Urban Development Office of Labor Relations

OMB Approval No. 2501-0009
(exp. 10/31/2010)

Public reporting burden for this collection of information is estimated to average 15 minutes per response, including the time for reviewing instructions, searching existing data sources, gathering and maintaining the data needed, and completing and reviewing the collection of information. This agency may not collect this information, and you are not required to complete this form, unless it displays a currently valid OMB control number. The information is collected to ensure compliance with the Federal labor standards by recording interviews with construction workers. The information collected will assist HUD in the conduct of compliance monitoring; the information will be used to test the veracity of certified payroll reports submitted by the employer. **Sensitive Information.** The information collected on this form is considered sensitive and is protected by the Privacy Act. The Privacy Act requires that these records be maintained with appropriate administrative, technical, and physical safeguards to ensure their security and confidentiality. In addition, these records should be protected against any anticipated threats or hazards to their security or integrity that could result in substantial harm, embarrassment, inconvenience, or unfairness to any individual on whom the information is maintained. **The information collected herein is voluntary, and any information provided shall be kept confidential.**

1a. Project Name		2a. Employee Name			
1b. Project Number		2b. Employee Phone Number (including area code)			
1c. Contractor or Subcontractor (Employer)		2c. Employee Home Address & Zip Code			
		2d. Verification of identification? Yes <input type="checkbox"/> No <input type="checkbox"/>			
3a. How long on this job?	3b. Last date on this job before today?	3c. No. of hours last day on this job?	4a. Hourly rate of pay?	4b. Fringe Benefits?	4c. Pay stub?
				Vacation Yes <input type="checkbox"/> No <input type="checkbox"/> Medical Yes <input type="checkbox"/> No <input type="checkbox"/> Pension Yes <input type="checkbox"/> No <input type="checkbox"/>	Yes <input type="checkbox"/> No <input type="checkbox"/>

5. Your job classification(s) (list all) --- continue on a separate sheet if necessary

6. Your duties

7. Tools or equipment used

	Y	N		Y	N
8. Are you an apprentice or trainee?	<input type="checkbox"/>	<input type="checkbox"/>	10. Are you paid at least time and 1/2 for all hours worked in excess of 40 in a week?	<input type="checkbox"/>	<input type="checkbox"/>
9. Are you paid for all hours worked?	<input type="checkbox"/>	<input type="checkbox"/>	11. Have you ever been threatened or coerced into giving up any part of your pay?	<input type="checkbox"/>	<input type="checkbox"/>

12a. Employee Signature	12b. Date
-------------------------	-----------

13. Duties observed by the interviewer (Please be specific.)

14. Remarks

15a. Interviewer name (please print)	15b. Signature of Interviewer	15c. Date of interview
--------------------------------------	-------------------------------	------------------------

Payroll Examination

16. Remarks

17a. Signature of Payroll Examiner	17b. Date
------------------------------------	-----------

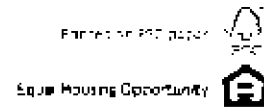

214 Roosevelt Avenue, P.O. Box 1303, Pawtucket, Rhode Island 02862-1303
Phone: 401-721-6000 • Fax: 401-723-3970 • TDD: 800-745-5555 • Web: www.pawthousing.org

Date:

Contractor Name & Address

Re: Contractual Liability Risk Management

It is our policy to identify and effectively manage our contractual liabilities arising out of business relationships with Contractors. We seek to take responsibility for our own actions and their consequences, while requiring our business partners to assume a share of risk relative to their ability to control it.

Given the number of contractual relationships that we may have at any point in time, it is imperative that we control the type and magnitude of the liabilities we assume. Conversely, we will look for opportunities to ensure that where legally possible, we manage our risks by asking others to contractually assume their share of liability. The effective management of these liabilities will allow us to lower our overall cost of risk. This program is a vital element of our overall safety and risk management program.

In order to perform as a Contractor for us, we will require a certificate of insurance from you meeting or exceeding the requirements on the attached sample certificate. We will require that we have additional insured coverage on your general liability policy for ongoing (CG 2010) and completed operations (CG 2037) or their equivalent on a primary and non-contributory basis and that the additional insured status be shown on the certificate of insurance as indicated on the sample. We will also require that we be an additional insured on a primary and non-contributory basis on your commercial auto policy and umbrella policy and a certificate holder on your workers compensation policy as shown on the sample certificate. Finally, we require a waiver of Subrogation in our favor on the General Liability, Auto Liability, Umbrella and Workers Compensation/Employers Liability. If you are an architect or engineer we will require that the certificate include evidence of a professional/pollution liability policy as well.

The following Hold Harmless and Indemnity Agreement, as evidenced by your (the Contractors') signature below, hereby applies to all work performed by the Contractor on our behalf, whether or not a separate work order or contract has been signed or agreed to between the parties:

To the fullest extent permitted by law, the Contractor hereby acknowledges and agrees that it shall indemnify, hold harmless and defend The Housing Authority of the City of Pawtucket, Rhode Island and any of their commissioners, officers, directors, employees, agents, affiliates, subsidiaries and partners, from and against all claims, damages, losses and expenses, including but not limited to, attorney's fees, arising out of or resulting from the performance of the Contractor's work, provided that any such claim, damage, loss or expense (1) is attributable to bodily injury, sickness, disease or death or to the destruction of tangible property (other than to the work itself) including loss of use resulting there from, and (2) is caused in whole or in part by any acts or omissions of the Contractor, its employees, agents or sub-contractors or anyone directly or indirectly employed by any of them, or for anyone whose acts any of them may be liable.

The Contractor hereby acknowledges its obligation under the foregoing paragraphs to provide the Certificate(s) of Insurance meeting the specified requirements and to indemnify The Housing Authority of the City of Pawtucket, Rhode Island against judgments suffered because of the Contractors work while assuming the cost of defending The Housing Authority of the City of Pawtucket, Rhode Island against claims as described in the foregoing paragraphs.

Contractor Name:
Title:
Date:

We must receive the required Certificate of Insurance meeting all the requirements, as well as the Contractors signature above accepting the terms of our Hold Harmless and Indemnity Agreement, prior to the beginning of any work.

If you have any questions on the above requirements, please contact Chris Bostic at (401) 640-1485.

Sincerely,

Paula McFarland
Executive Director



CERTIFICATE OF LIABILITY INSURANCE

DATE (MM/DD/YYYY)

Current Date

THIS CERTIFICATE IS ISSUED AS A MATTER OF INFORMATION ONLY AND CONFERS NO RIGHTS UPON THE CERTIFICATE HOLDER. THIS CERTIFICATE DOES NOT AFFIRMATIVELY OR NEGATIVELY AMEND, EXTEND OR ALTER THE COVERAGE AFFORDED BY THE POLICIES BELOW. THIS CERTIFICATE OF INSURANCE DOES NOT CONSTITUTE A CONTRACT BETWEEN THE ISSUING INSURER(S), AUTHORIZED REPRESENTATIVE OR PRODUCER, AND THE CERTIFICATE HOLDER.

IMPORTANT: If the certificate holder is an **ADDITIONAL INSURED**, the policy(ies) must have **ADDITIONAL INSURED** provisions or be endorsed. If **SUBROGATION IS WAIVED**, subject to the terms and conditions of the policy, certain policies may require an endorsement. A statement on this certificate does not confer rights to the certificate holder in lieu of such endorsement(s).

PRODUCER Contractor Insurance Agent 123 Main Street Anytown State Zip	CONTACT NAME: PHONE (A/C. No., Ext.): FAX (A/C. No.): E-MAIL ADDRESS	
	INSURER(S) AFFORDING COVERAGE NAIC #	
INSURED Contractor Name Address City State Zip	INSURER A: ABC Insurance Company	
	INSURER B: DEF Insurance Company	
	INSURER C: GHI Insurance Company	
	INSURER D: JKL Insurance Company	
	INSURER E:	

COVERAGES CERTIFICATE NUMBER: REVISION NUMBER:

THIS IS TO CERTIFY THAT THE POLICIES OF INSURANCE LISTED BELOW HAVE BEEN ISSUED TO THE INSURED NAMED ABOVE FOR THE POLICY PERIOD INDICATED. NOTWITHSTANDING ANY REQUIREMENT, TERM OR CONDITION OF ANY CONTRACT OR OTHER DOCUMENT WITH RESPECT TO WHICH THIS CERTIFICATE MAY BE ISSUED OR MAY PERTAIN, THE INSURANCE AFFORDED BY THE POLICIES DESCRIBED HEREIN IS SUBJECT TO ALL THE TERMS, EXCLUSIONS AND CONDITIONS OF SUCH POLICIES. LIMITS SHOWN MAY HAVE BEEN REDUCED BY PAID CLAIMS.

INSR LTR	TYPE OF INSURANCE	ADDL	SUBR	POLICY NUMBER	POLICY EFF (MM/DD/YYYY)	POLICY EXP (MM/DD/YYYY)	LIMITS
A	<input checked="" type="checkbox"/> COMMERCIAL GENERAL LIABILITY <input type="checkbox"/> CLAIMS-MADE <input checked="" type="checkbox"/> OCCUR GENL AGGREGATE LIMIT APPLIES PER POLICY: <input checked="" type="checkbox"/> PROJ <input type="checkbox"/> LOC OTHER:	X	X	Policy Number	Current	Date	EACH OCCURRENCE \$ 1,000,000 DAMAGE TO RENTED PREMISES (Per occurrence) \$ 100,000 VEH EXP (Any one person) \$ 5,000 PERSONAL & ADV INJURY \$ 1,000,000 GENERAL AGGREGATE \$ 2,000,000 PRODUCTS - CCVPH OF AGG \$ 2,000,000 \$
B	AUTOMOBILE LIABILITY <input checked="" type="checkbox"/> ANY AUTO <input type="checkbox"/> OWNED AUTOS ONLY <input type="checkbox"/> SCHEDULED AUTOS <input checked="" type="checkbox"/> HIRED AUTOS ONLY <input checked="" type="checkbox"/> NON OWNED AUTOS ONLY <input type="checkbox"/> AUTOS ONLY	X	X	Policy Number	Current	Date	COMMUN. PROP. & TYP (Per accident) \$ 1,000,000 BODILY INJURY (Per person) \$ BODILY INJURY (Per accident) \$ PROPERTY DAMAGE (Per accident) \$ \$
A	<input checked="" type="checkbox"/> UMBRELLA LIAB <input checked="" type="checkbox"/> OCCUR <input type="checkbox"/> EXCESS LIAB <input type="checkbox"/> CLAIMS-MADE DEB RETENTION \$	X	X	Policy Number			EACH OCCURRENCE \$ 2,000,000 AGGREGATE \$ 2,000,000 \$
C	WORKERS COMPENSATION AND EMPLOYERS' LIABILITY ANY PROPRIETOR/PARTNER/EXECUTIVE OFFICER/MEMBER EXCLUDED? (Mandatory in NH) If yes, describe under DESCRIPTION OF OPERATIONS below	N/A	X	Policy Number	Current	Date	<input checked="" type="checkbox"/> PER STATUTE <input type="checkbox"/> OTHER E.L. EACH ACCIDENT \$ 1,000,000 E.L. DISEASE - EACH EMPLOYEE \$ 1,000,000 E.L. DISEASE - POLICY LIMIT \$ 1,000,000 Per Claim Aggregate

DESCRIPTION OF OPERATIONS / LOCATIONS / VEHICLES (ACORD 101, Additional Remarks Schedule, may be attached if more space is required)

Certificate Holder is included as an Additional Insured on a primary and non-contributory basis on the General Liability policy for Ongoing Operations (CG2013) and Completed Operations (CG2037) or their equivalent. Certificate holder is included as an additional insured a primary and non-contributory basis on the on Automobile and Umbrella policies. The Additional Insured Coverage shall not require a contract between the certificate holder and the insured. The Commercial General Liability, Automobile Liability, Umbrella Liability and Employers Liability all include a Waiver of Subrogation in favor of certificate holder. All insurance carriers affording coverage are approved to do business in the State of Rhode Island and have an AM Best Rating of not less than A X.

CERTIFICATE HOLDER**CANCELLATION**

The Housing Authority of the City of Pawtucket, Rhode Island 214 Roosevelt Avenue Pawtucket RI 02862-1303	SHOULD ANY OF THE ABOVE DESCRIBED POLICIES BE CANCELLED BEFORE THE EXPIRATION DATE THEREOF, NOTICE WILL BE DELIVERED IN ACCORDANCE WITH THE POLICY PROVISIONS.
	AUTHORIZED REPRESENTATIVE Must be signed

© 1988-2015 ACORD CORPORATION. All rights reserved.

Logo Here

SECTION 3 POLICY

The Housing Authority of the City of Pawtucket
214 ROOSEVELT AVE PAWTUCKET, RI 02861

Office: (401) 721-6000 Website: <https://www.pawthousing.org>

INTERNAL PROCEDURES, INSTRUCTIONS, AND FORMS

This packet is designed to comply with the New HUD Section 3 Final Rule issued September 29, 2020, and became effective November 30, 2020. Therefore, these documents and instructions are related to the “Hours Worked Benchmarks” as called for in the 24 CFR Part 75 regulation. Every contractor and sub-contractor (with the exception of professional services) are required to work toward meeting the prescribed benchmarks as indicated on the bottom of page 10 of this packet. **There are no specific hiring or contracting goals under this new rule.**

Most importantly, **the rule does not require the hiring or contracting of any person or business that is not fully qualified** to perform the work as would be charged. However, the rule makes clear that HUD is intent on ensuring Section 3 persons employed under the new rule receive measurable and sustainable employment. Therefore, Section 3 employees can be counted for up to five full years from the date of certification or hire respectively. HUD is expected to issue continued guidance on the new rule in the future so these documents may change in accordance with the rule.

If you should have any questions on this packet, please contact our Compliance Consultant:

Cecelia M. Swiney-Horne, Compliance Manager

Motivation, Inc.

678-350-5460

cswiney@motivation-inc.com

Prepared January 28, 2022

Board Approved: _____

GOVERNING PARTS OF THE SECTION 3 FINAL RULE SPECIFIC TO THE
 THE HOUSING AUTHORITY OF THE CITY OF PAWTUCKET
 The Final Rule is at 24 CFR Part 75

Policy Section	Page
<hr/>	
Section 3 Background	3
✳ Internal Hiring Procedure	3
✳ Internal Contracting Procedure	4
✳ Internal Resident Training Procedure	4
Subpart A—General Provisions	
§ 75.1 Purpose	5
§ 75.3 Applicability	5
§ 75.5 Definitions	6
Subpart B—Additional Provisions for Public Housing Financial Assistance	
§ 75.9 Requirements.	8
§ 75.11 Targeted Section 3 worker for public housing financial assistance.	9
§ 75.13 Section 3 safe harbor.	9
§ 75.15 Reporting.v	9
§ 75.17 Contract provisions.	11
Subpart D—Provisions for Multiple Funding Sources, Recordkeeping, and Compliance	
§ 75.29 Multiple funding sources.	11
§ 75.31 Recordkeeping	12
✳ Benchmarks	13
Contract and Solicitation Inclusion Section	Page
<hr/>	
✳ New Requirements Summary	15
✳ Monthly Reporting Instructions	16
✳ Section 3 Business Self-Certification Forms	17
✳ Section 3 Individual Self-Certification Forms	18
✳ Hours Worked Reporting Form	19
✳ Acknowledgment and Affidavit Form	20

SECTION 3 BACKGROUND

Applicable to all expenditures and agreements regardless of the dollar amount

Background - Section 3 of the Housing and Urban Development Act of 1968 (Public Law 90-448, approved August 1, 1968) (Section 3) was enacted to bring economic opportunities generated by certain HUD financial assistance expenditures, to the greatest extent feasible, to low- and very low-income persons residing in communities where the financial assistance is expended. Section 3 recognizes that HUD funds are often one of the largest sources of Federal funds expended in low- and very low-income communities and, where such funds are spent on activities such as construction and rehabilitation of housing and other public facilities, the expenditure results in economic opportunities. By directing HUD-funded economic opportunities to residents and businesses in the community where the funds are expended, the expenditure can have the dual benefit of creating new or rehabilitated housing and other facilities while providing opportunities for employment and training for the residents of these communities.

The Section 3 statute establishes priorities for employment and contracting for public housing programs and for other programs that provide housing and community development assistance. For example, the prioritization as it relates to public housing assistance places an emphasis on public housing residents, in contrast to the prioritization as it relates to housing and community development assistance, which places more emphasis on residents of the neighborhood or service area in which the investment is being made.

INTERNAL PROCEDURES FOR IMPLEMENTATION OF THE RULE

The Housing Authority of the City of Pawtucket Internal Hiring Procedure

For all positions at the authority, the human resources staff will include the Section 3 Individual Low-Income Person Self Certification form with the applications (virtually and paper) allowing each applicant to identify themselves accordingly. The completion of the form will remain voluntary and at the applicants discretion.

Once all applications have been received and reviewed, the most desirous and qualified candidate will be progressed through the hiring process. The Section 3 status of the applicant will be considered only after the "Most Qualified" candidate has been determined.

If there are multiple and equally qualified persons, the Section 3 status and category of the applicant will be considered. The candidate with the highest Section 3 priority based on the 24CFR Part 75.9(a)(2) will be offered the position.

All advertisements for positions with the authority will carry this wording:

"This opportunity is covered under Section 3 of the HUD Act of 1968"

The Housing Authority of the City of Pawtucket Contracting Procedure

For all advertised contracts let by the authority, the responsible staff will include the Section 3 Business Self Certification form and the Section 3 Individual Low-Income Self Certification form with the bid package (virtually and paper) allowing each respondent to identify themselves and their business accordingly. The completion of the forms will remain voluntary and at the respondents discretion.

Once all responses have been received and reviewed, the most desirous and qualified business will be progressed through the contracting process. The Section 3 status of the respondent will be considered only after the "Most Qualified and Advantageous" respondent has been determined.

If there are multiple and equally qualified businesses, the Section 3 status and category of the business will be considered. The business with the highest Section 3 priority, based on the 24CFR Part 75.9 (b)(2) will be awarded the contract. All other applicable procurement laws will be adhered to relative to contracting amounts. All advertisements for contracts with the authority will carry this wording:

"This opportunity is covered under Section 3 of the HUD Act of 1968"

The Housing Authority of the City of Pawtucket Internal Resident Training Procedure

For all resident training offered by The Housing Authority of the City of Pawtucket and its contractors, the staff will include the Section 3 Individual Low-Income Person Self Certification form with the training notice or upon the first day of training (virtually and paper) allowing each prospective trainee to identify themselves accordingly as public housing or Section 8. The completion of the form will NOT be voluntary as the prospective trainees will be allowed to attend based on their prioritization in the 24CFR Part 75.9(a)(2).

If the training is being paid for with HUD Public Housing financial assistance, the training will be limited to residents and potentially voucher holders only.

All advertisements for training will carry this wording:

"This opportunity is covered under Section 3 of the HUD Act of 1968"

Key Rule Components

Note: Where a portion of a Section specifically spoke to areas not related to Public Housing Assistance, those pieces were intentionally removed. So there is no need to feel something important is not included.

§ 75.1 Purpose.

This part establishes the requirements to be followed to ensure the objectives of Section 3 of the Housing and Urban Development Act of 1968 (12 U.S.C. 1701u) (Section 3) are met. The purpose of Section 3 is to ensure that economic opportunities, most importantly employment, generated by certain HUD financial assistance shall be directed to low- and very low-income persons, particularly those who are recipients of government assistance for housing or residents of the community in which the Federal assistance is spent.

§ 75.3 Applicability.

(a) General applicability. Section 3 applies to public housing financial assistance and Section 3 projects, as follows:

(1) Public housing financial assistance. Public housing financial assistance means:

(i) Development assistance provided pursuant to section 5 of the United States Housing Act of 1937 (the 1937 Act);

(ii) Operations and management assistance provided pursuant to section 9(e) of the 1937 Act;

(iv) The entirety of a mixed-finance development project as described in 24 CFR 905.604, regardless of whether the project is fully or partially assisted with public housing financial assistance as defined in paragraphs (a)(1)(i) through (iii) of this section.

(iii) The requirements in this part apply to an entire Section 3 project, regardless of whether the project is fully or partially assisted under HUD programs that provide housing and community development financial assistance.

(b) Contracts for materials. Section 3 requirements do not apply to material supply contracts.

(d) Other HUD assistance and other Federal assistance. Recipients that are not subject to Section 3 are encouraged to consider ways to support the purpose of Section 3.

§ 75.5 Definitions.

The terms HUD, Public housing, Public Housing Agency (PHA), and are defined in 24 CFR part 5. The also apply to this part: 1937 Act means the United States Housing Act of 1937, 42 U.S.C. 1437 et seq. Contractor means any entity entering into a contract with:

- (1) A recipient to perform work in connection with the expenditure of public housing financial assistance or for work in connection with a Section 3 project; or
- (2) A subrecipient for work in connection with a Section 3 project.

Labor hours means the number of paid hours worked by persons on a Section 3 project or by persons employed with funds that include public housing financial assistance.

Low-income person means a person as defined in Section 3(b)(2) of the 1937 Act.

Material supply contracts means contracts for the purchase of products and materials, including, but not limited to, lumber, drywall, wiring, concrete, pipes, toilets, sinks, carpets, and office supplies.

Professional services means non-construction services that require an advanced degree or professional licensing, including, but not limited to, contracts for legal services, financial consulting, accounting services, environmental assessment, architectural services, and civil engineering services.

Public housing financial assistance means assistance as defined in § 75.3(a)(1).

Public housing project is defined in 24 CFR 905.108.

Recipient means any entity that receives directly from HUD public housing financial assistance or housing and community development assistance that funds Section 3 projects, including, but not limited to, any State, local government, instrumentality, PHA, or other public agency, public or private nonprofit organization.

Section 3 means Section 3 of the Housing and Urban Development Act of 1968, as amended (12 U.S.C. 1701u).

Section 3 business concern means:

- (1) A business concern meeting at least one of the following criteria, documented within the last six-month period:
 - (i) It is at least 51 percent owned and controlled by low- or very low-income persons;
 - (ii) Over 75 percent of the labor hours performed for the business over the prior three-month period are performed by Section 3 workers; or
 - (iii) It is a business at least 51 percent owned and controlled by current public housing residents or residents who currently live in Section 8-assisted housing.
- (2) The status of a Section 3 business concern shall not be negatively affected by a prior arrest or conviction of its owner(s) or employees.

(3) Nothing in this part shall be construed to require the contracting or subcontracting of a Section 3 business concern. Section 3 business concerns are not exempt from meeting the specifications of the contract.

Section 3 project means a project defined in § 75.3(a)(2).

Section 3 worker means:

(1) Any worker who currently fits or when hired within the past five years fit at least one of the following categories, as documented:

- (i) The worker's income for the previous or annualized calendar year is below the income limit established by HUD.
- (ii) The worker is employed by a Section 3 business concern.
- (iii) The worker is a YouthBuild participant.

(2) The status of a Section 3 worker shall not be negatively affected by a prior arrest or conviction.

(3) Nothing in this part shall be construed to require the employment of someone who meets this definition of a Section 3 worker. Section 3 workers are not exempt from meeting the qualifications of the position to be filled.

Section 8-assisted housing refers to housing receiving project-based rental assistance or tenant-based assistance under Section 8 of the 1937 Act.

Service area or the neighborhood of the project means an area within one mile of the Section 3 project or, if fewer than 5,000 people live within one mile of a Section 3 project, within a circle centered on the Section 3 project that is sufficient to encompass a population of 5,000 people according to the most recent U.S. Census.

Small PHA means a public housing authority that manages or operates fewer than 250 public housing units.

Subcontractor means any entity that has a contract with a contractor to undertake a portion of the contractor's obligation to perform work in connection with the expenditure of public housing financial assistance or for a Section 3 project.

Subrecipient has the meaning provided in the applicable program regulations or in 2 CFR 200.93.

Targeted Section 3 worker has the meanings provided in §§ 75.11, 75.21, or 75.29, and does not exclude an individual that has a prior arrest or conviction.

Very low-income person means the definition for this term set forth in section 3(b)(2) of the 1937 Act.

YouthBuild programs refers to YouthBuild programs receiving assistance under the Workforce Innovation and Opportunity Act (29 U.S.C. 3226).

§ 75.9 Requirements

(a) Employment and Training.

(1) Consistent with existing Federal, state, and local laws and regulations, PHAs or other recipients receiving public housing financial assistance, and their contractors and subcontractors, must make their best efforts to provide employment and training opportunities generated by the public housing financial assistance to Section 3 workers.

(2) PHAs or other recipients, and their contractors and subcontractors, must make their best efforts described in paragraph (a)(1) of this section in the following order of priority:

- (i) To residents of the public housing projects for which the public housing financial assistance is expended;
- (ii) To residents of other public housing projects managed by the PHA that is providing the assistance or for residents of Section 8-assisted housing managed by the PHA;
- (iii) To participants in YouthBuild programs; and
- (iv) To low- and very low-income persons residing within the metropolitan area (or nonmetropolitan county) in which the assistance is expended.

(b) Contracting.

(1) Consistent with existing Federal, state, and local laws and regulations, PHAs and other recipients of public housing financial assistance, and their contractors and subcontractors, must make their best efforts to award contracts and subcontracts to business concerns that provide economic opportunities to Section 3 workers.

(2) PHAs and other recipients, and their contractors and subcontractors, must make their best efforts described in paragraph (b)(1) of this section in the following order of priority:

- (i) To Section 3 business concerns that provide economic opportunities for residents of the public housing projects for which the assistance is provided;
- (ii) To Section 3 business concerns that provide economic opportunities for residents of other public housing projects or Section-8 assisted housing managed by the PHA that is providing the assistance;
- (iii) To YouthBuild programs; and
- (iv) To Section 3 business concerns that provide economic opportunities to Section 3 workers residing within the metropolitan area (or nonmetropolitan county) in which the assistance is provided.

§ 75.11 Targeted Section 3 worker for Public Housing Financial Assistance.

(a) Targeted Section 3 worker. A Targeted Section 3 worker for public housing financial assistance means a Section 3 worker who is:

(1) A worker employed by a Section 3 business concern; or

(2) A worker who currently fits or when hired fit at least one of the following categories, as documented within the past five years:

(i) A resident of public housing or Section 8-assisted housing;

(ii) A resident of other public housing projects or Section 8-assisted housing managed by the PHA that is providing the assistance; or

(iii) A YouthBuild participant.

§ 75.13 Section 3 Safe Harbor. (See Benchmarks on page 13)

(a) General. Recipients will be considered to have complied with requirements in this part, in the absence of evidence to the contrary if they:

(2) Certify that they have followed the prioritization of effort in § 75.9; and

(3) (2) Meet or exceed the applicable Section 3 benchmark as described in paragraph (b) of this section.

§ 75.15 Reporting. (See Benchmarks on page 13)

(a) Reporting of labor hours. (1) For public housing financial assistance, PHAs and other recipients must report in a manner prescribed by HUD:

(i) The total number of labor hours worked;

(ii) The total number of labor hours worked by Section 3 workers; and

(iii) The total number of labor hours worked by Targeted Section 3 workers.

(2) Section 3 workers' and Targeted Section 3 workers' labor hours may be counted for five years from when their status as a Section 3 worker or Targeted Section 3 worker is established pursuant to § 75.31.

(3) The labor hours reported under paragraph (a)(1) of this section must include the total number of labor hours worked with public housing financial assistance in the fiscal year of the PHA or other recipient, including labor hours worked by any contractors and subcontractors that the PHA or other recipient is required, or elects pursuant to paragraph (a)(4) of this section, to report.

(4) PHAs and other recipients reporting under this section, as well as contractors and subcontractors who report to PHAs and recipients, may report labor hours by Section 3 workers, under paragraph (a)(1)(ii) of this section, and labor hours by Targeted Section 3 workers, under paragraph (a)(1)(iii) of this section, from professional services without including labor hours from professional services in the total number of labor hours worked under paragraph (a)(1)(i) of this section. If a contract covers both professional services and other work and the PHA, other recipient, contractor, or subcontractor chooses not to report labor hours from professional services, the labor hours under the contract that are not from professional services must still be reported.

(5) PHAs and other recipients may report on the labor hours of the PHA, the recipient, a contractor, or a subcontractor based on the employer's good faith assessment of the labor hours of a full-time or part-time employee informed by the employer's existing salary or time and attendance based payroll systems, unless the project or activity is otherwise subject to requirements specifying time and attendance reporting.

(b) Additional reporting if Section 3 benchmarks are not met.

If the PHA's or other recipient's reporting under paragraph (a) of this section indicates that the PHA or other recipient has not met the Section 3 benchmarks described in § 75.13, the PHA or other recipient must report in a form prescribed by HUD on the qualitative nature of its Section 3 compliance activities and those of its contractors and subcontractors. Such *qualitative efforts may, for example,* include but are not limited to the following:

(1) Engaged in outreach efforts to generate job applicants who are Targeted Section 3 workers.

(2) Provided training or apprenticeship opportunities.

(3) Provided technical assistance to help Section 3 workers compete for jobs (e.g., resume assistance, coaching).

(4) Provided or connected Section 3 workers with assistance in seeking employment including: drafting resumes, preparing for interviews, and finding job opportunities connecting residents to job placement services.

(5) Held one or more job fairs.

(6) Provided or referred Section 3 workers to services supporting work readiness and retention (e.g., work readiness activities, interview clothing, test fees, transportation, child care).

(7) Provided assistance to apply for/or attend community college, a four-year educational institution, or vocational/technical training.

- (8) Assisted Section 3 workers to obtain financial literacy training and/or coaching.
- (9) Engaged in outreach efforts to identify and secure bids from Section 3 business concerns.
- (10) Provided technical assistance to help Section 3 business concerns understand and bid on contracts.
- (11) Divided contracts into smaller jobs to facilitate participation by Section 3 business concerns.
- (12) Provided bonding assistance, guaranties, or other efforts to support viable bids from Section 3 business concerns.
- (13) Promoted use of business registries designed to create opportunities for disadvantaged and small businesses.
- (14) Outreach, engagement, or referrals with the state one-stop system as defined in Section 121(e) (2) of the (c) Reporting frequency. Unless otherwise provided, PHAs or other recipients must report annually to HUD under paragraph (a) of this section, and, where required, under paragraph (b) of this section, in a manner consistent with reporting requirements for the applicable HUD program.
- (d) Reporting by Small PHAs. Small PHAs may elect not to report under paragraph (a) of this section. Small PHAs that make such election are required to report on their qualitative efforts, as described in paragraph (b) of this section, in a manner consistent with reporting requirements for the applicable HUD program.

§ 75.17 Contract Provisions.

- (a) PHAs or other recipients must include language in any agreement or contract to apply Section 3 to contractors.
- (b) PHAs or other recipients must require contractors to include language in any contract or agreement to apply Section 3 to subcontractors.
- (c) PHAs or other recipients must require all contractors and subcontractors to meet the requirements of § 75.9, regardless of whether Section 3 language is included in contracts.

§ 75.29 Multiple Funding Sources.

- (a) If a housing rehabilitation, housing construction or other public construction project is subject to Section 3 pursuant to § 75.3(a)(1) and (2), the recipient must follow subpart B of this part for the public housing financial assistance and may follow either subpart B or C of this part for the housing and community development financial assistance. For such a project, the following applies:

(2) The recipients of both sources of funding shall report on the housing rehabilitation, housing construction, or other public construction project as a whole and shall identify the multiple associated recipients. PHAs and other recipients must report the following information:

- (i) The total number of labor hours worked on the project;
- (ii) The total number of labor hours worked by Section 3 workers on the project; and
- (iii) The total number of labor hours worked by Targeted Section 3 workers on the project.

§ 75.31 Recordkeeping.

(b) Recipients must maintain documentation, or ensure that a subrecipient, contractor, or subcontractor that employs the worker maintains documentation, to ensure that workers meet the definition of a Section 3 worker or Targeted Section 3 worker, at the time of hire or the first reporting period, as follows:

(1) For a worker to qualify as a Section 3 worker, one of the following must be maintained:

- (i) A worker's self-certification that their income is below the income limit from the prior calendar year;
- (ii) A worker's self-certification of participation in a means-tested program such as public housing or Section 8-assisted housing;
- (iii) Certification from a PHA, or the owner or property manager of project-based Section 8-assisted housing, or the administrator of tenant-based Section 8-assisted housing that the worker is a participant in one of their programs;
- (iv) An employer's certification that the worker's income from that employer is below the income limit when based on an employer's calculation of what the worker's wage rate would translate to if annualized on a full-time basis; or
- (v) An employer's certification that the worker is employed by a Section 3 business concern.

(2) For a worker to qualify as a Targeted Section 3 worker, one of the following must be maintained:

(i) For a worker to qualify as a Targeted Section 3 worker under subpart B of this part:

(A) A worker's self-certification of participation in public housing or Section 8-assisted housing programs;

(B) Certification from a PHA, or the owner or property manager of project-based Section 8-assisted housing, or the administrator of tenant-based Section 8-assisted housing that the worker is a participant in one of their programs;

(C) An employer's certification that the worker is employed by a Section 3 business concern; or

(D) A worker's certification that the worker is a YouthBuild participant.

Benchmarks

For Public Housing Financial Assistance, the proposed benchmark notification set the benchmarks for the recipient's fiscal year. The proposed benchmark notification provided that recipients would meet the safe harbor in the new § 75.13 by certifying to the prioritization of effort in the new § 75.9 and meeting or exceeding Section 3 benchmarks for total number of labor hours worked by Section 3 workers and by Targeted Section 3 workers. The benchmark for Section 3 workers was set at 20 percent or more of the total number of labor hours worked by all workers paid with public housing financial assistance. The benchmark for Targeted Section 3 workers was set at 5 percent or more of the total number of labor hours worked by all workers paid with public housing financial assistance.

Simply stated, the recipient needs to meet these two benchmarks annually in order to achieve Safe Harbor.

Section 3 Workers Labor Hours = 20%
Total Labor Hours for the Recipient

Section 3 Targeted Workers Labor Hours = 5%
Total Labor Hours for the Recipient

Note: Motivation, Inc. is the Section 3 Consultant for The Housing Authority of the City of Pawtucket and will be launching an electronic method for contractors and the agency to enter their monthly Hours Worked data into their proprietary cloud-based Section 3 Compliance software. That system will mirror the information contained in the Contract Compliance Forms Package with the contractor or agency uploading any new Section 3 self-certification forms directly into the system for review and confirmation by Motivation, Inc. staff. This system is expected to go live on April 1, 2022, but will be tested prior to the live tested with real data from the client and its contractors.

Forms Package Follows on the Next Page

This Section Left Blank Intentionally

-CONTRACT COMPLIANCE FORMS PACKAGE-

SECTION 3 NEW RULE

24 CFR Part 75

On November 30, 2020, HUD put into effect a New and Final Section 3 Rule for all recipients. This rule is drastically different from the old rule and therefore, we want everyone to know these requirements and plan accordingly.

Every contractor must ensure this package is included in their sub-contracts. Every sub-contractor must include this package in their lower-tiered sub-contracts.

This new rule exempts all material and supply only agreements. The rule applies to all service related contracts/agreements despite the dollar amount or project duration, except CPA's, Attorneys, Engineers, and Architects.

You should not issue the Individual or Business Self-Certification form(s) until you have secured a qualified contractor or employee respectively. **DO NOT** hand the individual self-certification form to every employee as it may be a waste of time if they were not hired within the past five years and were low-income, public housing, or Section 8 at the time of hire.

Documents included in this package:

✱ New Requirements Summary	15
✱ Monthly Reporting Instructions	16
✱ Section 3 Business Self-Certification Forms	17
✱ Section 3 Individual Self-Certification Forms	18
✱ Hours Worked Reporting Form	19
✱ Acknowledgment and Affidavit Form	20

The Acknowledgement and Affidavit must be executed and returned by Every Contractor.

The Housing Authority of the City of Pawtucket
Annual "Section 3 Benchmarks" Requirement Summary

- ✱ Twenty (20) percent or more of the total number of labor hours worked by all workers employed with public housing financial assistance in a HA's fiscal year are Section 3 workers; and
- ✱ Five (5) percent or more of the total number of labor hours worked by all workers employed with public housing financial assistance in a HA's fiscal year are Section 3 workers;
- ✱ There are No specific hiring or contracting goals under this new rule.
- ✱ There is No Section 3 Business Preference under the new rule and No points awarded for being a Section 3 Business.
- ✱ The rule does not require the hiring or contracting of any person or business that is not fully qualified to perform the work.

The two new categories of Section 3 are now referred to as:

- ✱ **Section 3 Worker** - Any low or very low-income persons residing in the housing authority MSA
- ✱ **Targeted Section 3 Worker** - Public Housing, Voucher Holder, YouthBuild participant

Contractors will provide these three (3) data sets to the The Housing Authority of the City of Pawtucket's Section 3 Consultant within 40 days of the month after the hours have been worked by EVERY person that worked directly on the contract. (**Ex:** April data is required by June 10th) No back-office staff hours are counted:

- ✱ Total Hours Worked by all workers
- ✱ Total Hours Worked by Section 3 Workers (Individual Self-Certification Form Required)
- ✱ Total Hours worked by Targeted Section 3 Workers (Individual Self-Certification Form Required)

There are new definitions of how to be a Section 3 Business Concern:

- ✱ It is at least 51 percent owned by low- or very low-income persons; with businesses at least 6 months old
- ✱ Over 75 percent of the labor hours performed for the business are performed by low- or very low-income persons; or (Based on the prior 90 days of full business payrolls)
- ✱ It is a business at least 51 percent owned by current public housing residents or residents who currently live in Section 8-assisted housing, with businesses at least 6 months old

MONTHLY REPORTING INSTRUCTIONS

STEP ONE

Enter your company name and the name of the contract or task you are performing in the appropriate lines at the top of the form.

STEP TWO

Determine which workers qualify as Section 3 by having each complete a **Section 3 Individual Low-Income Person Self-Certification Form**. This form is submitted once per Section 3 employee or those that believe they meet the definition of a Section 3 employee.

The form is to be completed by the individual and stress to the employee that the form is Voluntary:

1. Complete contact info section
2. Check the box that describes your situation
3. Sign and date the form
4. Complete the employer information
5. Return to your employer

STEP THREE

After determining which workers are Section 3, determine their classification based on what they check in the box on the form as **Non-Targeted** or **Targeted**:

Non-Targeted are those Section 3 income-qualified workers who are low-income and reside in the MSA.

Targeted are those Section 3 income-qualified workers who are low-income and reside in public housing, Section 8 or YouthBuild

STEP FOUR

Enter the monthly dates of reporting on the first line, then proceed as follows:

1. Enter total hours worked by ALL contract or project level staff with exceptions as noted above*
2. Enter total hours worked by all Section 3 staff Non-Targeted
3. Enter total hours worked by all Section 3 staff Targeted

List **ONLY** the individual names of the workers who have self-certified as Section 3 (Non-Targeted and Targeted) along with their total hours for this months report only.

Submit the Section 3 Hours Worked Reporting Form on a monthly basis to the contact person noted on your reporting form above.

SECTION 3 BUSINESS

Voluntary Self-Certification Form

IN COMPLIANCE WITH SECTION 3 OF THE HUD ACT OF 1968 UPDATED 24 CFR PART 75 11/30/2020

The purpose of this form is to comply with Section 3 of the HUD Act of 1968 Business Certification requirements. To count as a Section 3 Business your company/firm must meet one of the listed categories below. Each category will require additional documentation to support the election. You must provide that supporting documentation with this form properly completed to be confirmed as a Section 3 business. If this form is submitted without the required supplemental data, your certification will not be processed.

CATEGORY	DOCUMENTATION REQUIRED	YOUR ELECTION
a business at least 51 percent owned by low- or very low-income persons;	Proof of ownership showing all owners and their percentages and a completed Section 3 Individual Self-Certification form for all low- and very low-income owners	← I N I T
Over 75 percent of the labor hours performed for the business are performed by low- or very low-income persons; or	Provide the last 90 days full payrolls for the entire company, make a list of the names from the payrolls of the Section 3 workers, and provide a completed Section 3 Individual Self- Certification for all low- and very low-income workers you list	I A L ←
It is a business at least 51 percent owned by current public housing residents or residents who currently live in Section 8-assisted housing.	Proof of ownership showing all owners and their percentages and a Section 3 Individual Self-Certification form for all public housing and/or Section 8 owners	H E R E ←

I hereby certify to the US Department of Housing and Urban Development (HUD) that all of the information on this form is true and correct. I attest under penalty of perjury that my business meets the elected definition and understand proof of this information may be requested. If found to be inaccurate, I understand that I may be disqualified as a certified Section 3 business.

Full Name: _____

Company Name: _____

Street Address: _____

City: _____ State: _____ Zip: _____

Signature: _____

Date: _____

SECTION 3 INDIVIDUAL LOW-INCOME PERSON

Voluntary Self-Certification Form

IN COMPLIANCE WITH SECTION 3 OF THE HUD ACT OF 1968 UPDATED 24 CFR PART 75 11/30/2020

The purpose of this form is to comply with Section 3 of the HUD Act of 1968 self-certification income requirements. To count as a Section 3 individual, any legal resident of the United States annual income must not exceed the HUD income limits for the year before they were hired, or, the individual's current year income annualized for the year they are being confirmed as low-income.

Print Name _____

Phone _____

Email _____

Address _____

City _____

State _____

Zip _____

To qualify as a Section 3 Person, you must meet one of the standards in the brackets below and your individual annual income must not exceed the number in the box below.

Check only one box below that describes your situation:

I am a Public Housing Resident, Section 8 assists me with my rent, or I am a current YouthBuild participant

I receive No HUD support, but I am low-income and live in the Pawtucket MSA

My Individual Annual Income does not exceed: \$48,450*

I hereby certify to the US Department of Housing and Urban Development (HUD) that all of the information on this form is true and correct. I attest under penalty of perjury that my total income is as shown above, and that proof of this information may be requested. If found to be inaccurate, I understand that I may be disqualified as an applicant and/or a certified Section 3 individual. Finally, I authorize including my name on a list of Section 3 Residents seeking employment and to include my contact information so that contractors may contact me directly for any employment opportunities.

Signature: _____

Date: _____

Income Limits website: <https://www.huduser.gov/portal/datasets/il/il2021/2021summary.odn>

SECTION 3

Hours Worked Reporting Form

IN COMPLIANCE WITH SECTION 3 OF THE HUD ACT OF 1968 UPDATED 24 CFR PART 75 11/30/2020

The purpose of this form is to comply with Section 3 of the HUD Act of 1968 tracking of hours worked by all person's employed by _____ (company name) on the _____ contract including those meeting the Section 3 income requirements as low- or very low-income.

Section 3 Employees are now defined to as:

Section 3 Workers - are those Section 3 income-qualified workers who are low-income and reside in the MSA.

Targeted Section 3 Workers - are those Section 3 income-qualified workers who are low-income and reside in public housing, Section 8 or YouthBuild.

If your company employs any person you believe is low income now or was when they were hired within the past five years, please have them complete the **SECTION 3 INDIVIDUAL LOW-INCOME PERSON SELF-CERTIFICATION FORM** and return it immediately.

All hours worked by everyone on the project must be reported monthly to:

Section 3 Compliance Consultant:
Motivation, Inc.
Cecelia M. Swiney-Horne, Compliance Manager
cswiney@motivation-inc.com
678-350-5460

Total Hours Worked by non-Section 3 staff

Total hours worked by all Non-targeted Section 3 employees

Total hours worked by all Targeted Section 3 employee

Please list the names and hours worked by each Section 3 Worker individually below or on a separate sheet.

First Name	Last Name	Total Hours This Period

Are You Attaching any New Contractor or Resident Self-Certification Forms to this month's report? Yes or No

Bidders and Respondents Solicitation

Section 3 New Rule Contractor Acknowledgement and Affidavit

(Return this form with your Bid/Quote/Response)

Company Name: _____ Solicitation #: _____

I hereby certify to the US Department of Housing and Urban Development (HUD) and The Housing Authority of the City of Pawtucket that I have read all of the information in this policy package and agree to follow the requirements for complying with the order of prioritization in 75.9 and reporting of all labor hours associated with my contract as required. I further understand that failure to comply with these requirements will cause my payments to be held and not processed or not released until I come into full compliance with this policy.

Monthly, I will be required to provide these data points for all contract staff working directly on the contract not including any back-office staff:

- Total Hours Worked by all employees (Section 3 and regular employees)
- Total Hours Worked by All Targeted Section 3 employees (Public Housing, Section 8, and YouthBuild)
- Total Hours Worked by All Non-Targeted Section 3 employees (Low Income persons residing in the Metropolitan Statistical Area)

You are required to enter the names and hours worked by each Section 3 employee individually.

Signature: _____ Print: _____ Date: _____

STATE OF _____ in _____ COUNTY)

I, the undersigned authority, a Notary Public in and for said County and in said State, hereby certify that, _____, whose name as _____ of _____ is signed to the foregoing conveyance and who is known to me, acknowledged before me on this day, that, being informed of the contents of the foregoing conveyance, he/she, in his/her capability as _____ (Title), and with full authority, executed the same voluntarily for and as the act of said corporation.

Given under my hand and official seal, this the _____ day of _____, 20_____.

Notary Public

My Commission Expires _____

Pawtucket Housing Authority

2024 Holiday Schedule

<u>Day</u>	<u>Date</u>	<u>Holiday</u>
Monday	01/01/2024	New Year's Day
Monday	01/15/2024	Martin Luther King
Monday	02/19/2024	President's Day
Monday	05/27/2024	Memorial Day
Wednesday	06/19/2024	Juneteenth
Thursday	07/04/2024	Independence Day
Monday	08/12/2024	Victory Day
Monday	09/02/2024	Labor Day
Monday	10/14/2024	Columbus Day
Monday	11/11/2024	Veteran's Day
Wednesday	11/27/2024	Thanksgiving Eve - 1/2 Day
Thursday	11/28/2024	Thanksgiving Day
Friday	11/29/2024	Day after Thanksgiving
Tuesday	12/24/2024	Christmas Eve - 1/2 Day
Wednesday	12/25/2024	Christmas Day
Tuesday	12/31/2024	New Year's Eve - 1/2 Day

SPECIAL CONDITIONS

INDEX TO THE SPECIAL CONDITIONS

<u>ARTICLE NO.</u>	<u>TITLE</u>
1	ENUMERATION OF DRAWINGS, SPECIFICATIONS AND ADDENDA
2	INTERFERENCE WITH EXISTING STRUCTURES
3	CLEANING FINISHED WORK
4	INSURANCES
5	REMEDIES
6	REQUIRED SUBMITTALS
7	TIME FOR COMPLETION AND LIQUIDATED DAMAGES

ARTICLE 1: ENUMERATION OF DRAWINGS, SPECIFICATIONS AND ADDENDA

The following are the Drawings, Specifications, and Addenda that form a part of this Contract, as set forth in Article 1 of the General Conditions of these Contract Documents.

- a. GENERAL CONDITIONS
- b. SPECIAL CONDITIONS
- c. TECHNICAL SPECIFICATIONS
- d. DESIGN PLANS PREPARED BY VERDANTAS

ADDENDA:

No. Dated:
No. Dated:

ARTICLE 2: INTERFERENCE WITH EXISTING STRUCTURES

Whenever it may be necessary to interfere with existing structures needing special care, due notice shall be given to the Owner, and the work shall be done according to his directions. Whenever required, all objects shall be strengthened to meet any additional stress that the work herein specified may impose upon it, and any damage caused shall be thoroughly repaired.

The Contractor shall repair and be responsible for correcting all damages to existing structures at no additional cost to the Owner.

All damaged items of work or items required to be removed and replaced due to construction shall be replaced or repaired by the Contractor to the complete satisfaction of the Owner, and at no additional expense to the Owner.

Under no circumstances will the Contractor interfere in any manner with the normal daily operations of the fire station facility.

ARTICLE 3: CLEANING FINISHED WORK

After the work is completed, all construction areas shall be carefully cleaned free of debris and dirt, rubbish, construction material, and left in first class condition, ready to use. All temporary or excess materials shall be disposed of off-site and the work area left to the satisfaction of the Owner.

ARTICLE 4: INSURANCES

The Contractor shall provide the following insurance in accordance with Article 82 of the General Conditions:

a. WORKMEN'S COMPENSATION INSURANCE

The Contractor shall provide adequate statutory Workmen's Compensation Insurance, in accordance with M.G.L. c.149, s.34A, for all labor employed on the project who may come within the protection of such laws and shall provide Employer's General Liability Insurance in the amount of \$100,000 for the benefit of his employees not protected by such compensation laws.

b. CONTRACTOR'S COMPREHENSIVE PUBLIC LIABILITY AND PROPERTY DAMAGE LIABILITY INSURANCE

*Pawtucket Housing Authority
Kennedy Manor Waste Pipe Replacements
Pawtucket, Rhode Island*

The Contractor shall carry Comprehensive General Liability Insurance with broad form of Contractual General Liability Endorsement attached, providing for a limit of not less than One Million Dollars (\$1,000,000.00) for all damages arising out of bodily injuries to or death of one person, and subject to that limit for each person, a total limit of not less than One Million Dollars (\$1,000,000.00) for all damages arising out of bodily injuries to or the death of two or more persons in any one accident; and Contractor's Comprehensive Property Damage Liability Insurance providing for a limit of not less than One Million Dollars (\$1,000,000.00) for all damages arising out of injury to or destruction of property in any one accident; and subject to a limit of not less than One Million Dollars (\$1,000,000.00) for all damages arising out of injury to or destruction of property during the policy period.

c. OWNER'S PROTECTIVE LIABILITY AND PROPERTY DAMAGE INSURANCE

The Contractor shall provide the Owner an insurance policy written in the name of the Owner, its employees, servants, and agents, and extended to include the interests of Resource Control Associates, Inc.; its employees, and agents; to protect the Owner and the Engineer from any liability which might be incurred against them as a result of any operations of the Contractor or his subcontractors or their employees. Such insurance shall provide for a limit of not less than One Million Dollars (\$1,000,000.00) for all damages arising out of bodily injuries to or the death of any one person, and subject to that limit for each person, a total limit of not less than One Million Dollars (\$1,000,000.00) for all damages arising out of bodily injuries to or the death of two or more persons in any one accident; and a limit of not less than One Million Dollars (\$1,000,000.00) for all damages arising out of injury to or destruction of property in any one accident, and subject to a limit of not less than One Million Dollars (\$1,000,000.00) for all damages arising out of injury to or destruction of property during the policy period.

d. COMPREHENSIVE AUTOMOBILE LIABILITY AND PROPERTY DAMAGE INSURANCE

The Contractor shall carry Comprehensive Automobile Liability Insurance covering all owned vehicles, hired vehicles, or non-owned vehicles in the amount of not less than One Million Dollars (\$1,000,000.00) for all damages arising out of bodily injuries to or the death of any one person; and subject to that limit for each person a total of not less than One Million Dollars (\$1,000,000.00) for all damages arising out of bodily injuries to or the death of two or more persons in any one accident; and Property Damage coverage in the amount of not less than One Million Dollars (\$1,000,000.00) for all damages arising out of injury to or destruction of property.

e. INSURANCE COVERING SPECIAL HAZARDS

Special hazards shall be covered by rider or riders to the Public Liability Insurance and Property Damage Insurance policy or policies herein above required to be furnished by the Contractor, or by separate policies of insurance as follows:

1. Property Damage Liability arising out of the collapse of, or structural injury to any building or structure due to excavation (including borrowing, filling, or back-filling in connection therewith), tunneling, pile driving, cofferdam work, or caisson work, or to moving, shoring, underpinning, razing, or demolition of any building or structure or removal or rebuilding of any structural support thereof.
2. Property Damage Liability for injury to or destruction of property arising, directly or indirectly, from blasting or explosions, however caused, other than explosions of air or steam vessels, piping under pressure, prime movers, machinery or power transmitting equipment.

3. Property Damage Liability for injury or destruction of wires, conduits, pipes, mains, sewers, or other similar property or any apparatus in connection therewith, below the surface of the ground, arising from and during the use of mechanical equipment for the purpose of excavating or drilling within the project limits; injury to or destruction of property at any time resulting there from.
4. The Contractor shall require similar insurance in such amounts to be taken out and maintained by each subcontractor.

f. FIRE INSURANCE

During the progress of work the Contractor shall effect and maintain BUILDER'S RISK INSURANCE ON COMPLETED VALUE FORM against loss by fire, lightning, windstorm, hurricane, cyclone, tornado, hail, explosion, riot, riot attending strike, aircraft, smoke and vehicle damage, vandalism and malicious mischief upon all work in place and all material stored at the building site, whether or not covered by partial payments made by the Owner. This insurance shall be in an amount equal to 100 percent of the insurable portion of the project and shall be for the benefit of the Owner, the Contractor and each Subcontractor as their interest may respectively appear.

If there are any existing adjacent or adjoining structures presently used by the Owner, the risk of the existing adjacent or adjoining structures will be by the Owner.

ARTICLE 5: REMEDIES

REFER TO GENERAL CONDITIONS, ARTICLE 9

ARTICLE 6: REQUIRED SUBMITTALS

The following submittals shall be made in accordance with Article 71 of the General Conditions:

DRAWINGS – Three (3) copies of shop drawings for all materials and equipment to be incorporated into the work shall be submitted to the engineer for review and approval.

ARTICLE 7: TIME FOR COMPLETION AND LIQUIDATED DAMAGES

It is extremely important that the required work be completed within the time frame established by this contract. In the event the contractor fails to deliver the required work within the established schedule, the contractor shall pay liquidated damages in the amount of \$300.00 per calendar day for each day in excess the stated completion date.

END OF SPECIAL CONDITIONS

DIVISION 01 – GENERAL REQUIREMENTS

GENERAL REQUIREMENTS INDEX

SECTION	DESCRIPTION
01000	Summary of Work
01150	Measurement and Payment
01175	Temporary Facilities
01200	As-Built Drawings
01300	Submittals
01400	Quality Controls
01600	Delivery Storage and Handling

SECTION 01000
SUMMARY OF WORK

PART 1.00 - GENERAL

1.01 DESCRIPTION

The Pawtucket Housing Authority Kennedy Manor Waste Pipe Replacements project consists of removing and disposing the existing 2" copper waste pipes and replacing them with new 1-1/2" and 2" schedule 40 PVC pipes. Site work shall take place at the subject property located at 175 Broad Street, Pawtucket, RI. The work encompassed by this contract shall include but is not limited to the following.

1. Coordinating with the Housing Authority for accessibility to specified buildings and proper staging areas.
2. Mobilization of all applicable equipment staged within the agreed upon location;
3. Coordination and submittals of all required shop drawings to the Engineer for approval;
4. Obtain all required State and Local permits;
5. Complete in-field measurements to verify prior to purchasing applicable materials;
6. Remove and dispose of $\pm 3'$ sections of drywall from floor to ceiling, or as needed to perform drain replacement for units one (1) through eleven (11) from floors A through H. If a railing is temporarily removed, it must be reinstalled by the end of each workday. The work area shall be covered with poly-sheeting if not completed by the end of each workday.
7. Remove and dispose existing 2" copper waste pipes, for units one (1) through eleven (11) from floors A through H.
8. Furnish and install new 1-1/2" and 2" schedule 40 PVC waste pipes to match existing plumbing and as shown on the design plans for units one (1) through eleven (11) from floors A through H.
9. Furnish and install new 5/8" gypsum board with seal compound to repair any removed or damaged drywall. Sand and paint to match existing conditions.
10. Furnish and install new 2" schedule 40 PVC pipe and no hub coupling to vent pipe from interior on Floor H.
11. Demobilize from the site following final inspection by the Owner's Representative.

Additionally, included within the scope of work is the following add alternate task:

1. In the event the owner chooses to add alternate item 1, Hallway Painting Per Floor, the Contractor shall prepare the west wing hallway for painting and apply two (2) new coats of paint.

1.02 SPECIAL REQUIREMENTS

- A. The Contractor will coordinate the construction schedule with the owner's representative to ensure that access to areas is permitted during the planned time.
- 7
- B. The Contractor shall be responsible for removing and protecting any equipment that may interfere with the construction operations. Immediately upon completion of construction activities in a given area, the contractor shall be responsible for returning the area to a pre-construction state satisfactory to the owner's representative.

*Pawtucket Housing Authority
Kennedy Manor Waste Pipe Replacements
Pawtucket, Rhode Island*

- C. Do not begin work when inclement weather is forecast to occur prior to the anticipated time of completion of the work item.

END OF SECTION

SECTION 01150
MEASUREMENT AND PAYMENT

PART 1 GENERAL

- 1.1 This section describes the measurement of and the payment for the work to be done under the items listed in the Bid.
- 1.2 Each Unit or Lump-Sum Price stated in the Bid shall constitute full compensation for all labor, equipment, materials and all incidental and appurtenant work required or necessary to satisfactorily complete the specified work in the accordance with the Drawings and Specifications.
- 1.3 Appurtenant items of work shown on the Drawings or specified or required to complete the work but not listed separately under the list of items in the Bid shall be included in the cost of payment under the various applicable bid items of work and no separate payment will be made for such items. It shall be the responsibility of the Contractor to verify any missing or incomplete items.
- 1.4 All existing work removed or damaged by the Contractor's operations shall be replaced to the satisfaction of the Owner at no additional expense to the Owner.
- 1.5 The limits of work shown on the plans shall be considered to be the pay limits. If the Contractor carries work on beyond the designated limits without prior approval of the Owner or the Owner's Representative, then the Contractor shall restore that additional area at his own expense. Any work conducted beyond the specified pay limits, unless approved in writing by the Owner, shall not be measured for payment.
- 1.6 Estimated quantities of work or any other construction under this contract may change depending on actual field conditions. Any increase or decrease in quantities shall in no way affect this Contract, the unit price of the work item or give cause for claims or liabilities for damages.
- 1.7 Proposed items of work under this Contract are given for use in comparing bids and the right is especially reserved by the Owner to diminish them as may be deemed necessary or desirable by the Owner to meet available funding. Such changes to the proposed items of work shall in no way affect this Contract, nor give cause for claims or liabilities for damages.
- 1.8 The Owner has the right to delete any item or items from the Contract.
- 1.9 All unit prices and bids shall be representative of the work to be undertaken or of items to be supplied. Unbalanced bids shall not be permitted and may be basis for disqualification of the bid.
- 1.10 All work for this project is to be done in accordance with the latest edition of International Building Code as amended, and the specifications accompanying these Contract Documents. Standard details for this project are the details accompanying these Contract Documents.
- 1.11 The Contractor shall include the cost of other indirect and miscellaneous costs in his/her submitted bid items.

PART 2 MEASUREMENT AND PAYMENT

2.01 Bid Item 1. Remove & Replace Existing Waste Pipes

A. Measurement:

Remove & Replace Existing Waste Pipes shall be measured by each unit. The work measured under this item shall include but not be limited to, coordination with the Housing Authority and the Owner's Representative on shop drawing submittals and associated work hours and staging areas, post proper signage of possible hazards on site during construction, obtaining required State and Local permits prior to starting work, removal and disposal of approximately three (3) foot sections of drywall from floor to ceiling per unit, removal and disposal of existing 2" copper waste pipes, furnishing and installing new 1-1/2" and 2" schedule 40 PVC pipe to match existing plumbing and as shown on the design plans, furnishing and installing new 5/8" gypsum board with seal compound, sanded and painted to match existing conditions. Contractor shall reinstall any railings temporarily removed by the end of each working day and shall cover work area with poly-sheeting if not completed by the end of the working day. Contractor shall return the work areas to original site conditions upon completion following final inspection of the Owner's Representative, as well as all associated activities, completed and accepted by the Engineer.

B. Payment:

The accepted quantity for Bid Item 1 shall be paid for at the contract price of Each, complete and accepted, including labor, materials, tools, equipment and all other incidentals necessary to complete the work in accordance with the plans, as directed by the Engineer and to the satisfaction of the Owner.

PART 3 MEASUREMENT AND PAYMENT – ADD ALTERANTE

3.01 Add Alternate Bid Item 1. Hallway Painting Per Floor

A. Measurement:

Hallway Painting Per Floor shall be measured by each floor. The work measured under this item shall include but not be limited to, coordination with the Housing Authority and the Owner's Representative on shop drawing submittals and associated work hours and staging areas, post proper signage of possible hazards on site during construction, obtaining required State and Local permits prior to starting work, removal of all wallpaper, cleaning and preparing the surface for painting, painting two (2) coats of Sherwin-Williams, or approved equal, color to be selected by the Owner, from the ceiling to the floor along the entire hallway, returning the work areas to original site conditions upon completion following final inspection of the Owner's Representative, as well as all associated activities, completed and accepted by the Engineer.

B. Payment:

The accepted quantity for Add Alternate Bid Item 1 shall be paid for at the contract Each, complete and accepted, including labor, materials, tools, equipment and all other incidentals necessary to complete the work in accordance with the plans, as directed by the Engineer and to the satisfaction of the Owner.

END OF SECTION 01150

SECTION 01175
TEMPORARY FACILITIES

PART 1.00 - GENERAL

1.01 WORK INCLUDED

- A. The Contractor shall provide all temporary facilities enumerated herein or required for the proper completion of the work.
- B. Temporary facilities shall include but not limited to:
 - Sanitary Facilities
 - Electrical power
 - Lockable trailer/storage container

PART 2.00 - FACILITIES

2.01 SANITARY FACILITIES

- A. Adequate sanitary conveniences for use of workman on the premises, properly secluded from public observance, shall be provided and maintained by the Contractor, in accordance with local and state health requirements, and in such a manner and at such points as shall be approved by these authorities, and their use shall be strictly enforced. Sanitary waste shall be treated and disposed of in a manner satisfactory to the Owner and the local and state authorities. Under no circumstances shall sanitary wastes be allowed to flow on the surface of the ground.

2.02 ELECTRICAL POWER

- A. The Contractor shall provide all temporary electrical power required to operate equipment for the duration of the Contract.
- B. The securing of all permits and approvals from the regulating utility companies shall be the responsibility of the Contractor. All unauthorized sources of power, such as from neighboring homes, shall be prohibited.

2.03 LOCKABLE TRAILER/STORAGE CONTAINER

- A. The Contractor shall provide a lockable trailer/storage container to safely secure all new equipment and materials.
- B. The Engineer/Owner will designate the storage location.

2.04 REMOVALS

- A. The Contractor shall remove and properly dispose of all temporary facilities at the satisfactory completion of the Contract.
- B. All sites utilized for temporary facilities shall be restored to a condition satisfactory to the Owner.

END OF SECTION 01175

SECTION 01200
AS-BUILT DRAWINGS

PART 1.00 - GENERAL

1.01 WORK INCLUDED

- A. The work under this Section shall include the transmittal to the Engineer of all applicable data relative to as-built conditions as may be required by the Engineer.

PART 2.00 - PRODUCTS

- 2.01 As-built information as specified.

PART 3.00 - EXECUTION

3.01 MARKED-UP PRINTS

- A. The Engineer shall provide the Contractor with an extra set of prints of the Drawings to be used for indicating the locations, elevations and other as-built conditions.
- C. The marked-up prints shall be kept up to date on a daily basis and shall be available for the Owner's inspection at all times. Any inaccuracies or incomplete information shall be correct immediately.
- D. They shall be kept in a safe location by the Contractor, or at the Contractor's option, in the offices of the Owner.
- E. All markings on the prints shall be done neatly with a red pencil.
- F. After review of As-Built by the Engineer and an approval is given, the Engineer shall transmit the revised plans to the Owner via AutoCAD.

END OF SECTION

SECTION 01300
SUBMITTALS

PART 1 – GENERAL

1.00 REQUIREMENTS INCLUDED

- A. Submit Product Data, Samples and Certifications concurrently as required by Contract Documents and as reasonably requested by the Engineer.
- B. Prepare and submit to the Engineer no later than ten (10) calendar days after receipt of Notice to Proceed (NTP), a list of submittals required by each Specification Section in the Contract Agreement. Submit in accordance with this Section.
- C. Designate in schedule data dates for submission and review of shop drawings, product data and samples, and the date of return.

1.01 PRODUCT DATA

- A. Preparation
 - 1. Annotate each sheet to clearly identify specific product or part installed and specific data applicable to installation.
 - 2. Show performance characteristics and capacities.
 - 3. Show dimensions and clearances required.
 - 4. Indicate specified finish.
 - 5. Indicate only those sheets, which are pertinent to specific product(s) with product clearly identified.
- B. Manufacturer's standard schematic drawings and documents.
 - 1. Modify drawings and diagrams to delete information, which is not applicable to the Work.
 - 2. Supplement standard information to provide information, which is applicable to the Work.

1.02 SAMPLES

- A. Provide a minimum of three (3) office samples, or as otherwise indicated in the Technical Specifications, of sufficient size to clearly illustrate:
 - 1. Functional characteristics of the product, with integrally related parts and attachment devices.
 - 2. Full range of color, texture, and pattern.
 - 3. Samples shall be referenced to applicable section of the specifications.
 - 4. Sample of selected color, texture or finish is to be provided on 4" x 4" (or as appropriate) sample chip. Record sample to match actual material installed.

1.03 MANUFACTURER'S CERTIFICATION OF MATERIALS AND EQUIPMENT

- A. Certification is required for the following systems:
 - 1. Systems requiring certification will be specified in each of the Divisions of the Technical Specifications.

1.04 CONTRACTOR REVIEW

*Pawtucket Housing Authority
Kennedy Manor Waste Pipe Replacements
Pawtucket, Rhode Island*

- A. Contractor shall review all submittals prior to transmittal to the Engineer.
 - 1. The Contractor shall consecutively number all shop drawings and product data transmittals. Re-submittals would have the same number of the previous submittal followed by the suffix "A, B, C etc."
 - 2. The transmittal is to contain the project number and the applicable specification section for each product represented on the transmittal.
- B. Apply Contractor's stamp to submittals, initialed or signed by authorized person and dated, certifying: review of submittal, verification of products, field measurements and field construction criteria, and coordination of information within submittal with requirements of Work and the Contract Documents.
- C. Submittals without Contractor's stamp or submittals that, in the Engineer's opinion are incomplete, contain numerous errors, or have not been checked or have only been checked superficially, will be returned without comments. Delays resulting there from shall be solely the Contractor's responsibility.
- D. Clearly note proposed deviations from the Contract Documents on submittals. Submit listing identifying deviations in a format acceptable to the Engineer.
- E. Contractor shall be responsible to ensure quantities and dimensions shown on submittals comply with the requirements of the Contract Documents.

1.05 SUBMISSION REQUIREMENTS

- A. Make submittals promptly in accordance with approved schedule and in such sequence as to cause no delay in the Work. Submittals by Contractor shall be made only through the Engineer.
- B. Number of submittals required:
 - 1. Shop Drawings: Submit one (1) reproducible transparency (sepia) and three (3) opaque reproductions (prints) in addition to what the Contractor will require back.
 - 2. Product Data: Submit copies Contractor requires, plus three (3) originals that will be retained by the Engineer.
 - 3. Samples: Submit two (2) samples of each material or the number required in each specification section.
- C. Submittals shall contain:
 - 1. Date of submission and dates of any previous submissions.
 - 2. Project title and number.
 - 3. Contract identification number.
 - a. The names of:
 - b. Contractor.
 - c. Subcontractor.
 - d. Supplier.
 - e. Manufacturer.
 - 4. Identification of the product, with the specification section number.
 - 5. Field dimensions, clearly identified as such.
 - 6. Relation to adjacent or critical features of the Work or Materials.
 - 7. Applicable standards, such as ASTM or Federal Specification numbers.

8. Identification of deviations from Contract Documents and justification.
9. Identifications of revisions on re-submittals.
10. Additional information as required by Contract Documents.
11. An 8-in.x 3-in. blank space for Contractor and Engineer stamps.

D. Contractor's responsibility for deviations in submittals from requirements of Contract Documents is not relieved by Engineer and/or Engineer's review of submittals

E. Numbering system established by the Contractor shall be agreeable to Engineer.

1.06 RESUBMISSION REQUIREMENTS

A. Make any corrections or changes in the submittals required by the Engineer, mark number of submission, and resubmit as required until approved.

B. Product Data:

1. Revise initial data, and resubmit as specified for the initial submittal.
2. Indicate any changes which have been made other than those requested by the Engineer.
3. Mark number of submission and resubmit until accepted.

C. Samples: Submit new samples as required for initial submittal. Remove samples, which are "rejected" or designated "resubmit."

1.07 ENGINEER REVIEW RESPONSIBILITIES

A. The Engineer shall review submittals with responsible promptness in accordance with the requirements of the Project Manual.

B. Affix stamp and initials or signature, and indicate requirements for revisions and re-submittal, if any.

C. Return submittals to Contractor and Owner for distribution, or for resubmission within fourteen (14) days of original receipt.

1.08 SUBMITTAL LIST

A. Shop Drawings

1. Sherwin-Williams Paint, or approved equal.

END OF SECTION 01300

SECTION 01400
QUALITY CONTROL

PART 1 – GENERAL

1.00 RELATED DOCUMENTS

- A. Documents related to this section include, but are not limited to, General Conditions, Special Conditions, Bidding Documents, Technical Specifications and Drawings

1.01 QUALITY CONTROL

- A. The contractor shall be:
1. acceptable to the owner
 2. acceptable and approved by the material manufacturers / suppliers
- B. Any deficiencies noted during construction inspection must be corrected by the contractor and approved by the owner at no additional expense to the owner

1.02 FIELD QUALITY CONTROL

- A. The existing dimensions shown on the plans are approximated and used to describe the scope of work. The contractor shall verify all existing dimensions.
- B. Any discrepancies found must be submitted to the Engineer in writing.

1.03 RANDOM SAMPLING

- A. During the course of work, the owner / engineer may at their discretion secure samples of materials being used from containers at the job site and submit them to an independent laboratory for testing and comparison to specified materials.
- B. If test results prove that a material is not functionally equal to specified material:
1. The Contractor shall pay for all testing
 2. All materials having failed testing that have been installed will be removed and replaced with specified materials at no additional expense to the owner
 3. All materials having failed testing not installed will be removed from the job site and replaced with specified materials at no additional expense to the owner

PART 2 – PRODUCTS

2.00 GENERAL

- A. Comply with quality control, references, specifications and manufacturer's data. Where a conflict exists, the more stringent requirements govern.

PART 3 – EXECUTION

3.00 SUBMITTALS

- A. Provide property owner/engineer a letter from the material manufacturer indicating that the applicator is approved to install their products and will provide warranty for this installation

END OF SECTION 01400

SECTION 01600
DELIVERY, STORAGE AND HANDLING

PART 1 – GENERAL

1.00 RELATED DOCUMENTS

- A. Documents related to this section include, but are not limited to, General Conditions, Special Conditions, Bidding Documents, Technical Specifications and Drawings

PART 2 - DELIVERY, STORAGE AND HANDLING

2.00 DELIVERY OF MATERIALS

- A. Deliver materials to the job-site in new, dry, unopened and well marked containers showing product and manufacturer's name
- B. Deliver materials in sufficient quantity to allow continuity of work

2.01 STORAGE OF MATEIALS

- A. Remove plastic packing shrouds. Cover all stored materials with canvas tarp top to bottom. Secure tarps
- B. Ground Storage: store materials in a secure location as directed by owner/engineer to avoid interference with normal operations of the site

2.02 MATERIAL HANDLING

- A. Handle all materials on site to avoid bending, tearing, or other damage during transportation and installation
- B. Material handling equipment shall be selected and operated so as not to damage existing construction. Do not operate or situate material handling equipment in locations that will hinder smooth flow of vehicular or pedestrian traffic.
- C. Handle all materials in accordance with manufacturer's guidelines

2.03 ENVIRONMENTAL REQUIREMENTS

- A. Do not work when environmental conditions exceed the material manufacturer's guidelines
- B. Protect all unfinished work from rain, water or other harsh environmental conditions
- C. Any damage to materials or existing construction caused by the contractor's failure to protect such shall be repaired or replaced at no additional expense to the owner

END OF SECTION 01600

Appendix A

DESIGN PLANS



PAWTUCKET HOUSING AUTHORITY

PAWTUCKET HOUSING AUTHORITY WASTE PIPE REPLACEMENTS

175 BROAD STREET
PAWTUCKET, RHODE ISLAND

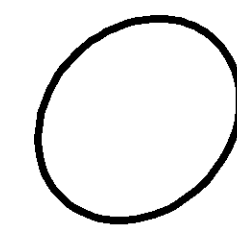

LOCATION MAP

NORTH

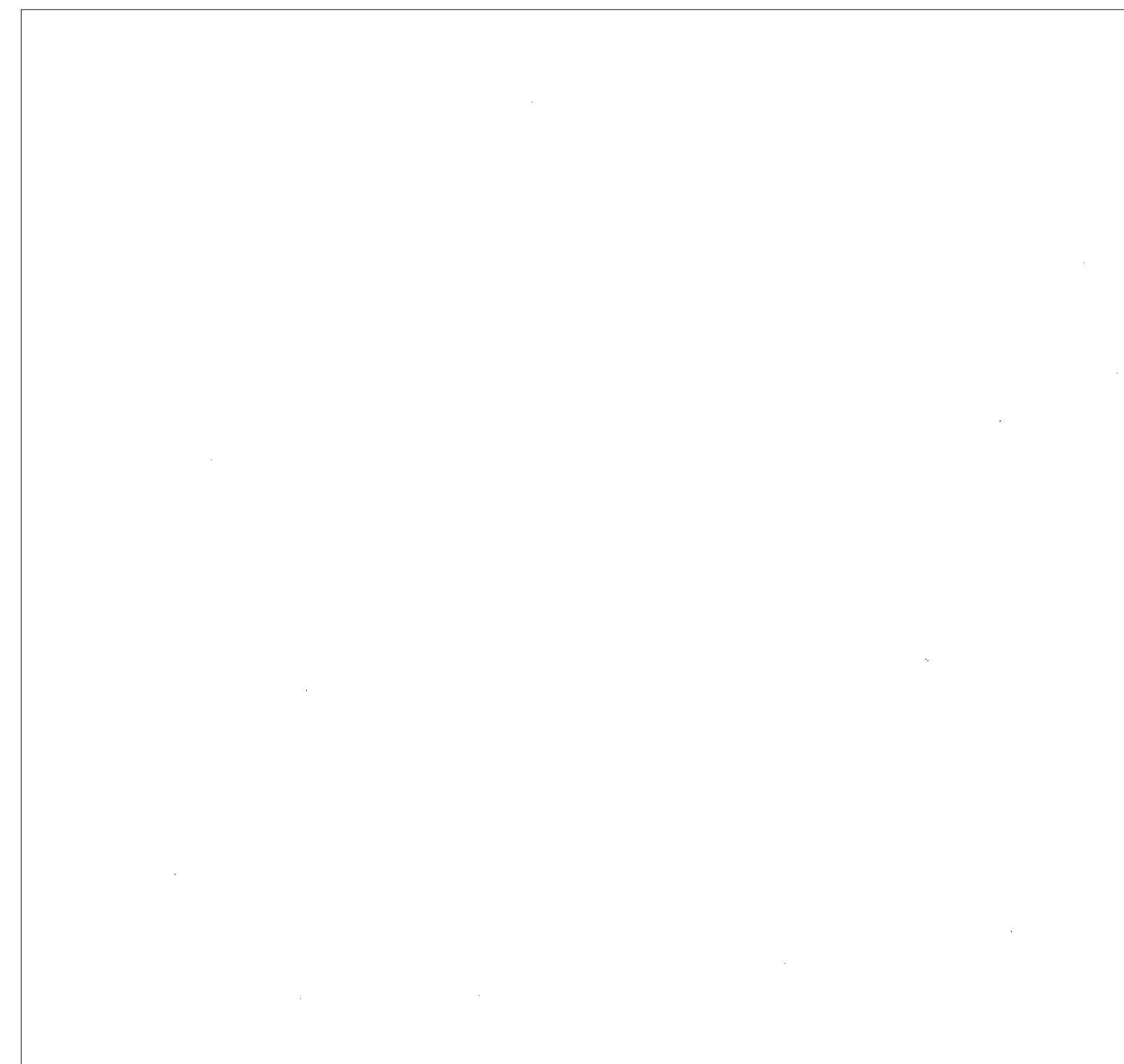

SITE MAP
NTS

INDEX OF DRAWINGS

DESCRIPTION	
WASTE PIPE REPLACEMENTS DESIGN PLANS	
CS	COVER SHEET
2	SITE MAP
3	PLAN DETAILS

PREPARED BY:

verdantas

1005 MAIN STREET, SUITE 8120
PAWTUCKET, RI 02860
TEL: 401.728.6860

PREPARED FOR:



PAWTUCKET HOUSING AUTHORITY
214 ROOSEVELT AVE
PAWTUCKET, RHODE ISLAND

OCTOBER
2024

BID
DOCUMENTS
OCTOBER
2024

Project No. 16965

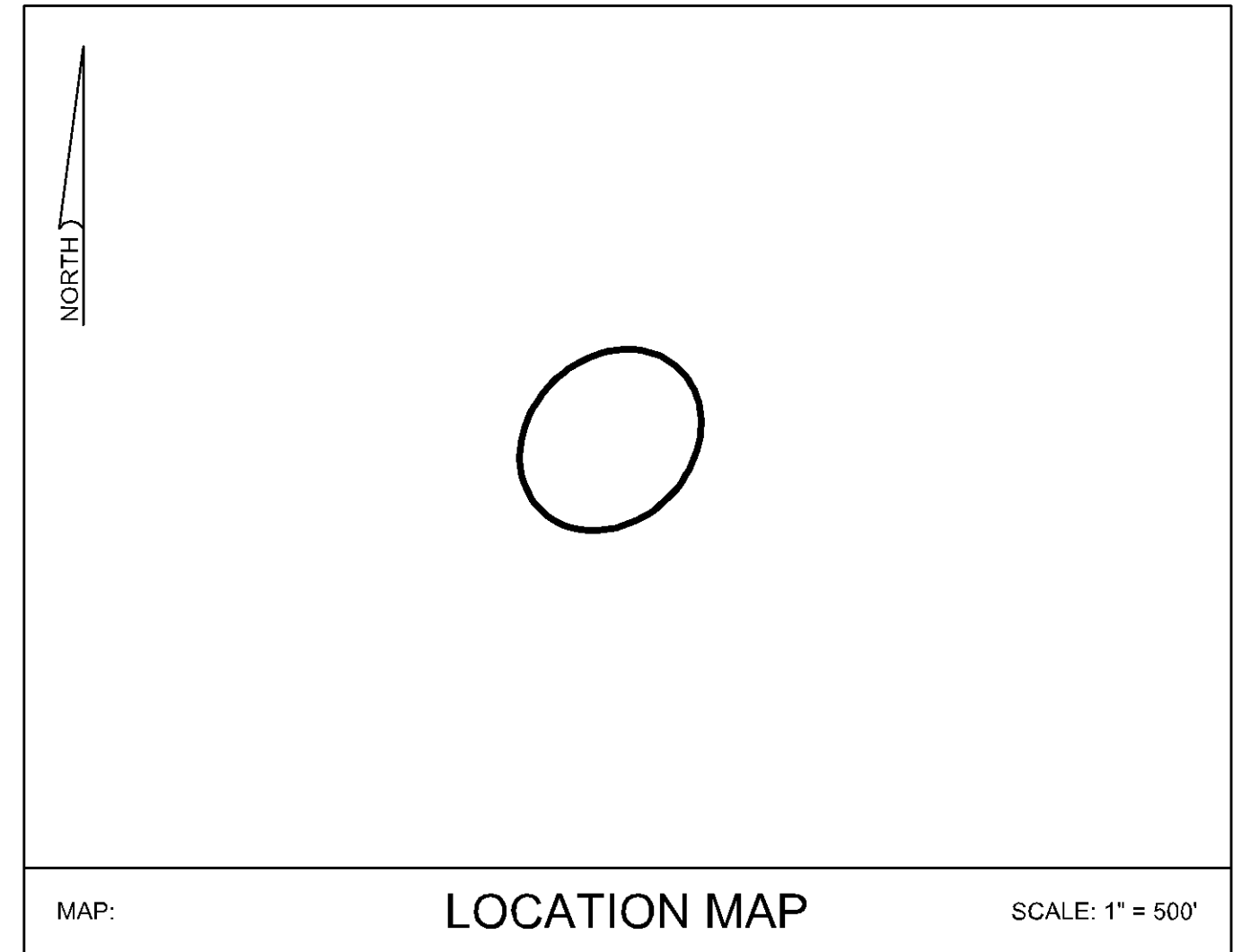
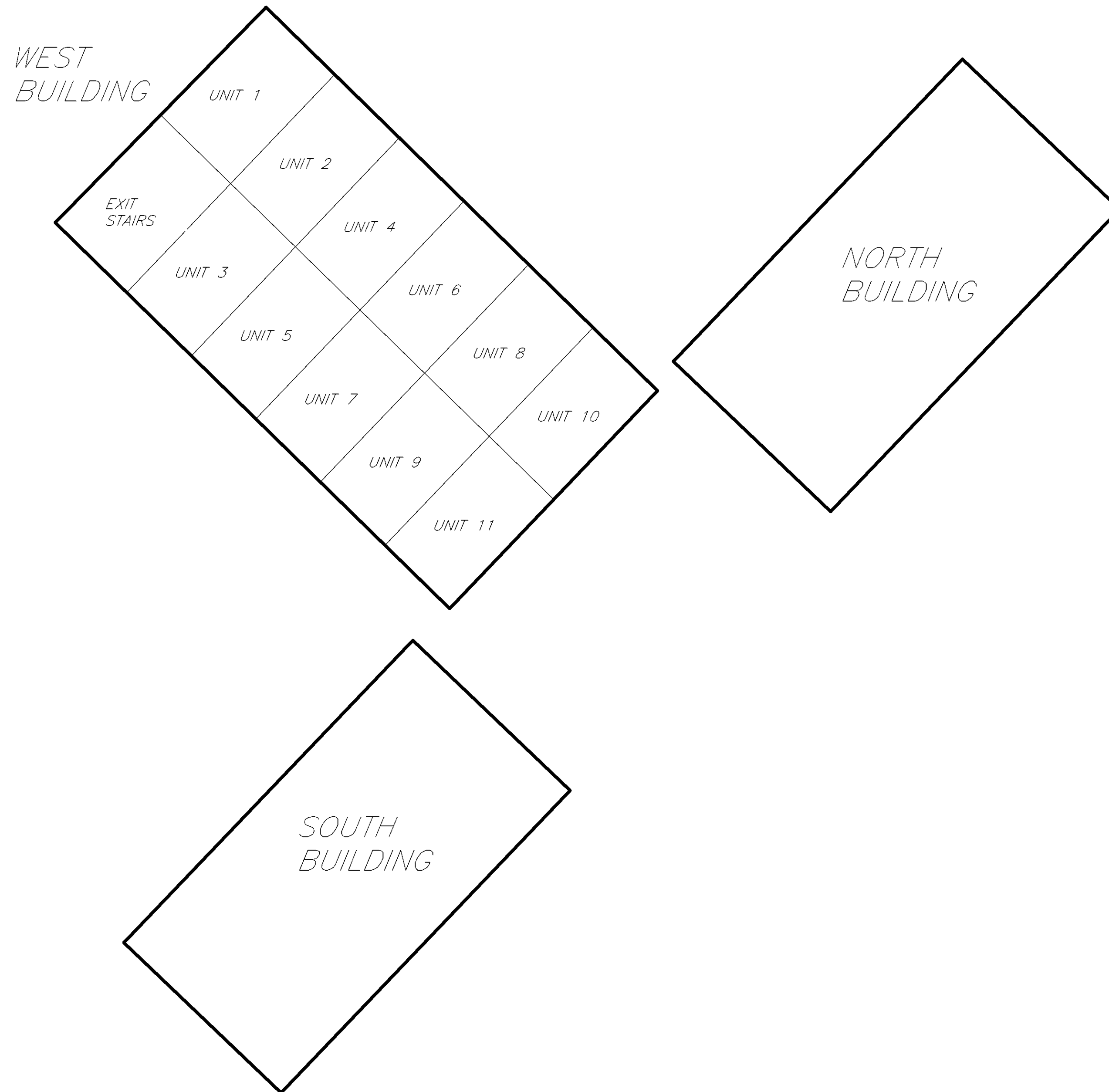

SCOPE OF WORK (BRIEF OVERVIEW)

- REMOVE AND DISPOSE OF EXISTING 2" COPPER WASTE PIPE BETWEEN FLOORS AND FROM UNITS, INCLUDING REMOVAL AND DISPOSAL OF EXISTING DRYWALL AS NEEDED. TEMPORARY REMOVAL OF RAILINGS IS PERMITTED BUT RAILING MUST BE RESECURED BY THE END OF THE WORKING DAY.
- FURNISH AND INSTALL NEW SCHEDULE 40 PVC PIPES TO MATCH EXISTING PLUMBING.
- REPAIR WALL OPENINGS CREATED WITH $\frac{5}{8}$ " GYPSUM BOARD AND PAINT TO MATCH EXISTING CONDITIONS.
- FURNISH AND INSTALL NEW 2" SCHEDULE 40 PVC PIPE AND NO HUB COUPLING TO ROOF DRAIN FROM INTERIOR ON FLOOR H.

ADD-ALTERNATE (BRIEF OVERVIEW)

- IN THE EVENT THE OWNER CHOOSES TO ADD ALTERNATE ITEMS 1-8, THE CONTRACTOR SHALL REMOVAL AND DISPOSE OF ALL WALLPAPER IN THE WEST WING, PREPARE THE WALLS FROM FLOOR TO CEILING FOR PAINTING, AND APPLY TWO (2) COATS OF SHERWIN-WILLIAMS, OR APPROVED EQUAL, COLOR TO BE SELECTED BY OWNER.

Floor	Number of Units
A	11
B	11
C	11
D	11
E	11
F	11
G	11
H	11
Total	88

NOTES:
1. UNITS SHOWN ARE APPROXIMATE AND ARE NOT TO SCALE.

DESIGNED BY	CHK'D BY	REVISION	No.
RSB	DATE		
DRAWN BY			
ENB			
CHECKED BY			
RSB			
PROJECT NO.			
16865			

PAWTUCKET-PROVIDENCE COUNTY-RHODE ISLAND
PAWTUCKET HOUSING AUTHORITY
WASTE PIPE REPLACEMENTS
KENNEDY MANOR
SITE MAP

DATE: OCTOBER 2024

SCALE: 1" = 20'

SHEET: 2 OF 3

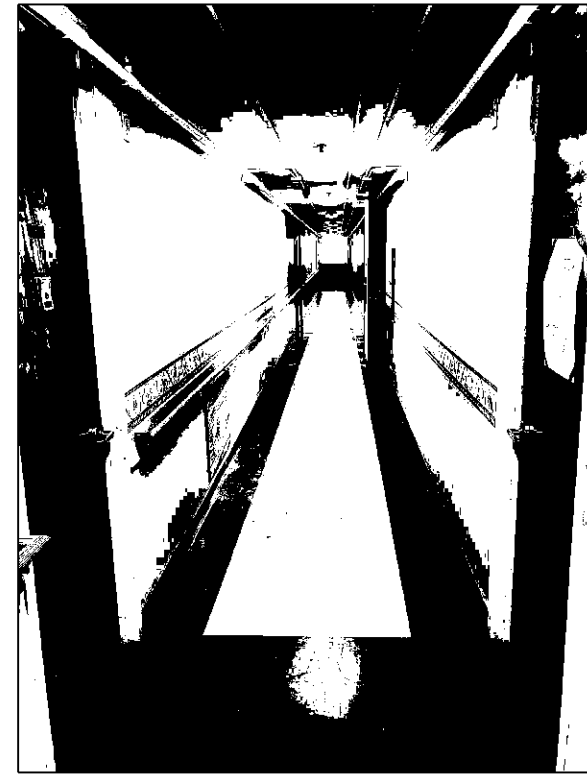

TYPICAL VIEW OF HALLWAY

1



TYPICAL VIEW OF DRYWALL IN HALLWAY

2

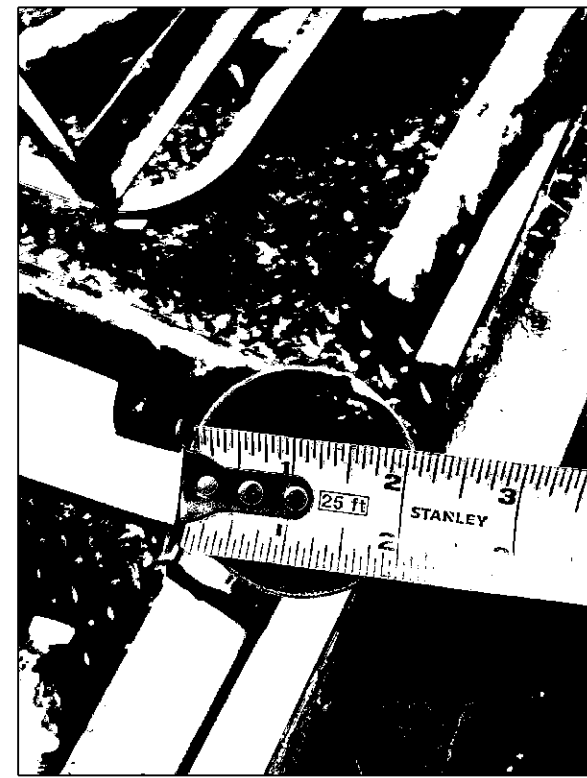

TYPICAL VIEW OF EXISTING PIPE

3

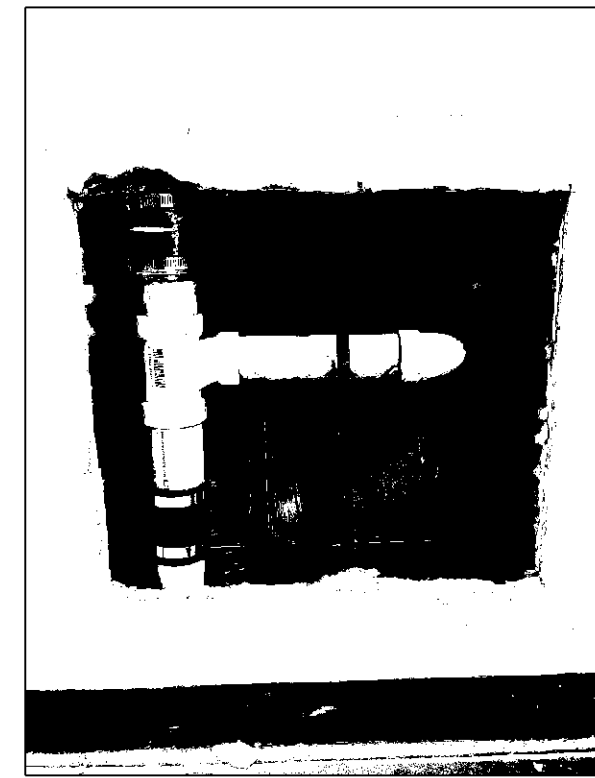

TYPICAL VIEW OF REPAIRED AREAS

4

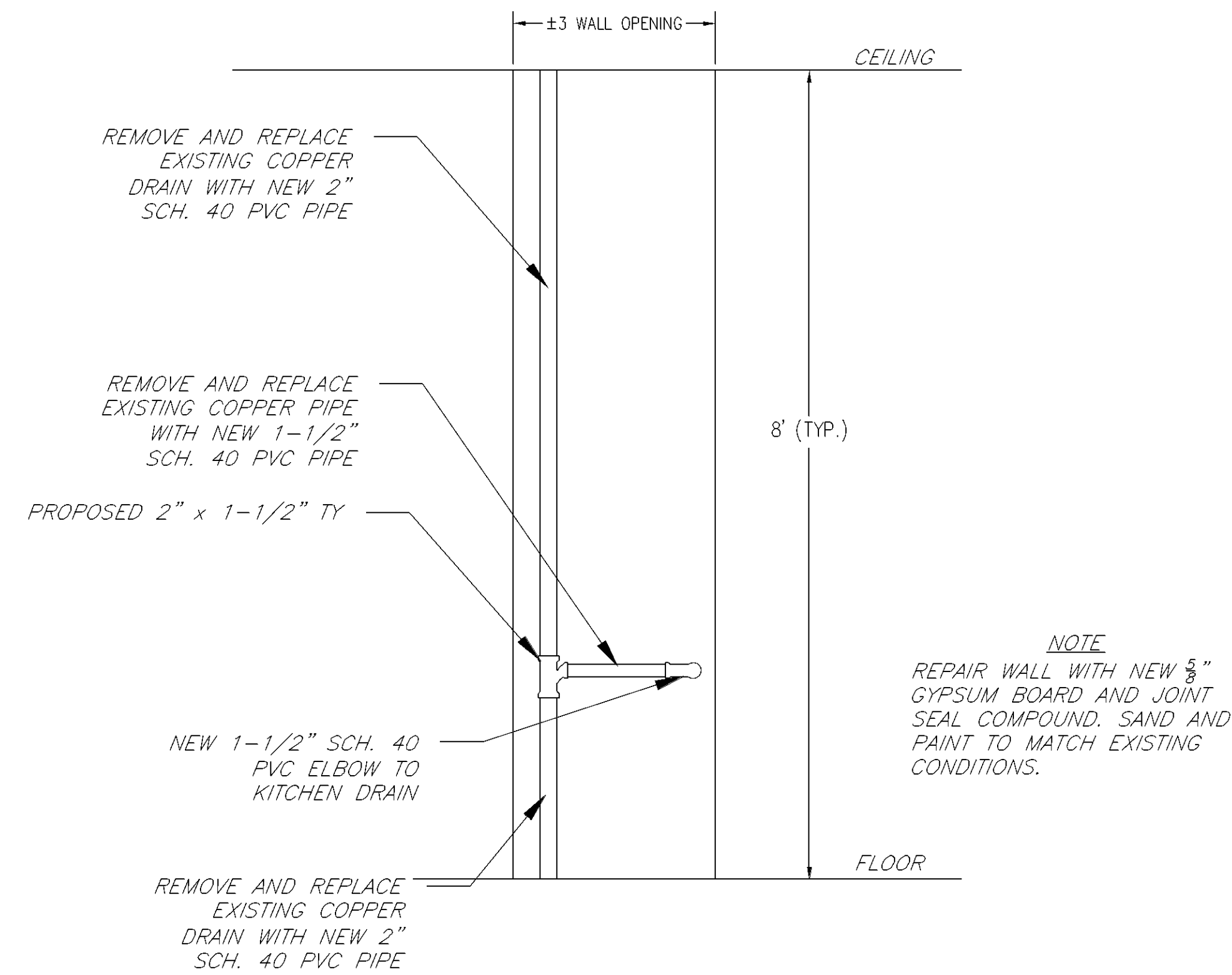

TYP. DRAIN REPAIR

NOT TO SCALE

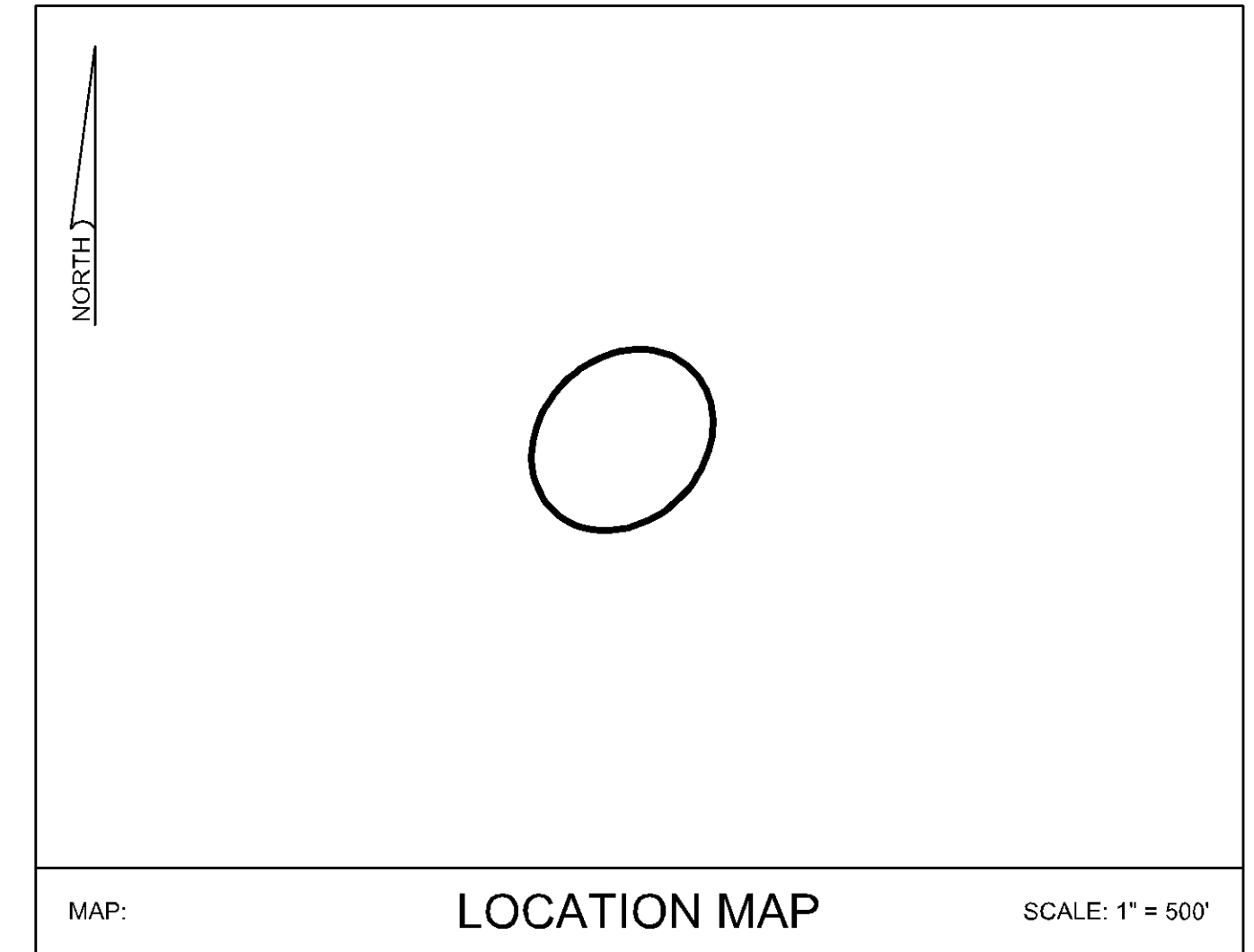

MAP:

LOCATION MAP

SCALE: 1" = 50'

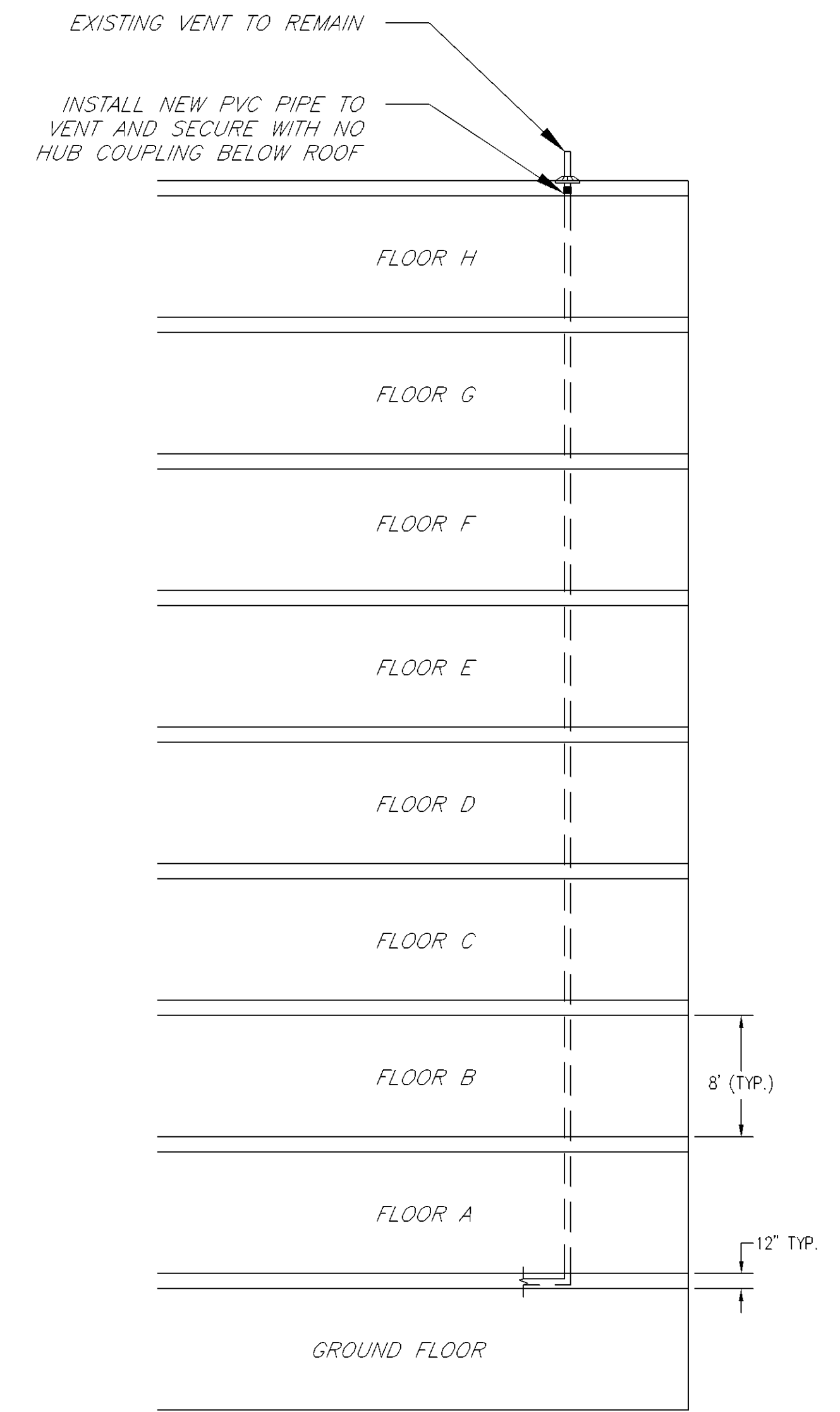
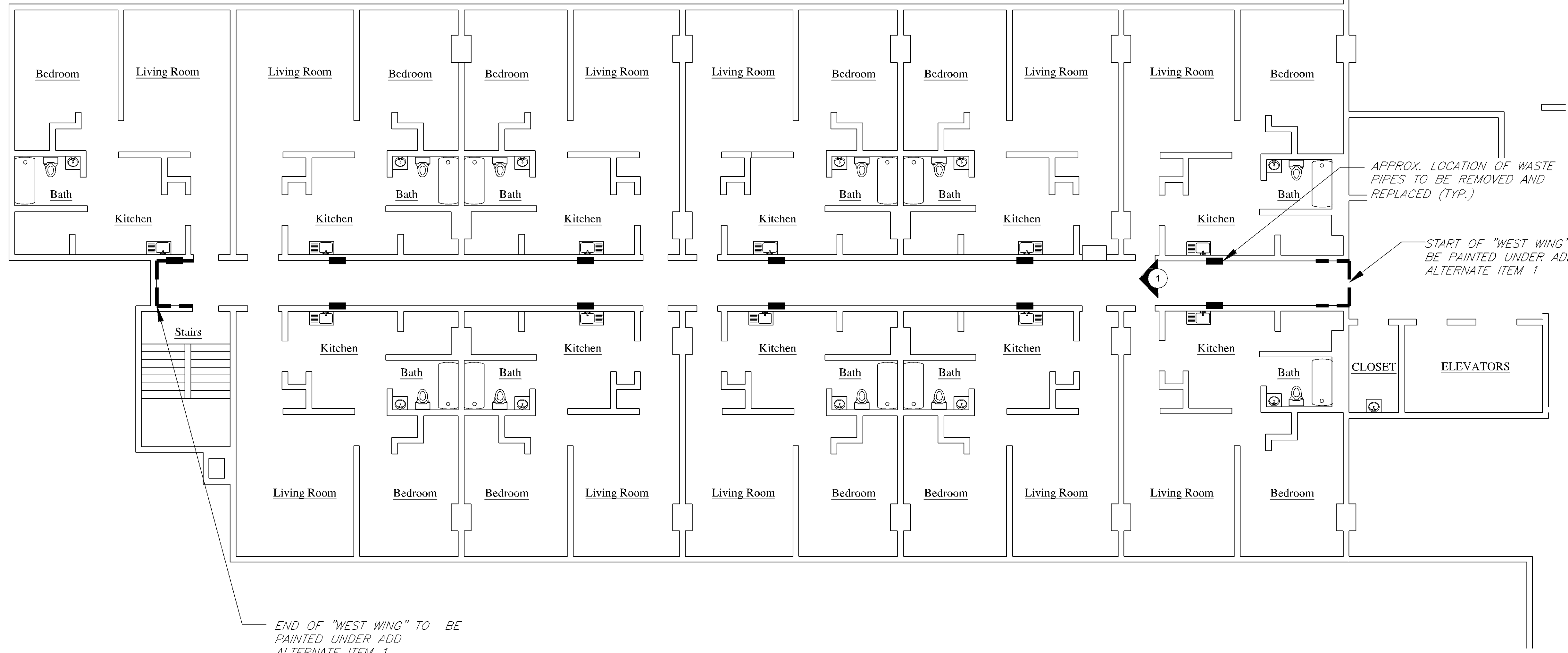

SECTION VIEW OF BUILDING

NOT TO SCALE

DESIGNED BY	CHK'D BY	REVISION	No.
RSB	DATE		
ENB			
RSB			
PROJECT NO.			
16895			

PAWTUCKET-PROVIDENCE COUNTY-RHODE ISLAND
PAWTUCKET HOUSING AUTHORITY
WASTE PIPE REPLACEMENTS
KENNEDY MANOR
PLAN DETAILS

Z:\project files\pa-hz\housing\16895 - kennedy manor wastepipe replacement\cad\plans and plans\16895_she plans_2024-07-18.dwg 10/7/2024 3:57 PM